



**HENRY SMITH
(CONSTRUCTIONAL ENGINEERS) LIMITED**

**SAFETY, HEALTH & ENVIRONMENTAL
POLICY AND PROCEDURES MANUAL**

Date: 01/01/11

Version 3

Published by
SAFETY FIRST CONSULTANTS LTD

Stanley Cottage
17 William Straw Gardens
Worksop
Nottinghamshire
S80 1HJ

Tel: 01909 478000
07879 447076

www.safetyfirstconsultants.co.uk

All rights reserved

This text is sold subject to the condition that it shall not, by way of trade or otherwise, be lent, re-sold, hired out or otherwise circulated in any form of binding or electronically without the publisher's prior consent.

The logo consists of a blue square with a gradient from dark blue at the top to light blue at the bottom. Inside the square, the words "SAFETY FIRST" are written in white, bold, uppercase letters, and "Consultants Ltd" is written in a smaller, white, sans-serif font below it.

SAFETY FIRST
Consultants Ltd

© Safety First Consultants Ltd
Copyright 2011

Contents

- 1.0 Health and Safety Policy Statement
 - Environmental Policy Statement
- 2.0 Organisation and Responsibilities
 - 2.1 Health and Safety Responsibility Structure
 - 2.2 Duties
- 3.0 Arrangements
 - 3.1 Risk Assessments/Method Statements/
Safe Systems of Work
 - 3.2 Consultation with Employees
 - 3.3 Workplace / Visitors / Induction
 - 3.4 Vehicles, Plant and Equipment
 - 3.5 Hazardous Substances
 - 3.6 Information, Instruction and Supervision
 - 3.7 Competency and Training
 - 3.8 Accident Reporting, First Aid and Work Related Ill
Health
 - 3.9 Monitoring, Review and Audit
 - 3.10 Emergency Procedures
 - 3.11 Welfare and Hygiene
 - 3.12 Construction (Design and Management) Regulations
2007
 - 3.13 Contractors and Sub Contractors
- 4.0 Risk Assessment
- 5.0 Procedures
 - 5.1 Abrasive Wheels
 - 5.2 Accidents / Incident Investigation
 - 5.3 Asbestos
 - 5.4 Burning and Welding
 - 5.5 Confined Spaces
 - 5.6 Control of Substances Hazardous to Health
 - 5.7 Deliveries, Loading and Shunting
 - 5.8 Display Screen Equipment (VDU's)
 - 5.9 Electricity and Electrical Equipment
 - 5.10 Energy and Machinery Isolation
 - 5.11 Environmental Procedures
 - 5.12 Erection of Structures

5.13 Fabrication

Contents (cont.)

- 5.0 Procedures (cont.)
 - 5.14 Fire Precautions
 - 5.15 First Aid
 - 5.16 Hand Tools
 - 5.17 Height Working
 - 5.18 Hot Work
 - 5.19 Housekeeping
 - 5.20 LPG & Oxygen
 - 5.21 Lifting Operations / Equipment
 - 5.22 Lone Working
 - 5.23 Machine Guarding
 - 5.24 Manual Handling
 - 5.25 Mobile Plant
 - 5.26 Noise
 - 5.27 Overhead / Underground Services
 - 5.28 Painting and Spraying
 - 5.29 Permit to Work
 - 5.30 Personal Protective Equipment (PPE)
 - 5.31 Plant and Equipment
 - 5.32 Pressure Systems
 - 5.33 Risk Assessment
 - 5.34 Safety Signs and Warning Notices
 - 5.35 Scaffolding and Mobile Towers
 - 5.36 Site Procedures
 - 5.37 Storage and Stacking
 - 5.38 Sub Contractors and Agency Workers
 - 5.39 Vibration
 - 5.40 Visitors
 - 5.41 Weather
 - 5.42 Welfare Facilities
 - 5.43 Workplace Access and Egress
 - 5.44 Young Persons

- 6.0 Safe Systems of Work
 - 6.1 Safe Systems of Work Index
 - SSW01 Manual Handling
 - SSW02 Isolation Procedure
 - SSW03 Hot Work
 - SSW04 Electrical Power Tools and Equipment
 - SSW05 Lifting Operations
 - SSW06 Electric Arc & Inert Gas Shield Welding
 - SSW07 Flame Cutting and Welding
 - SSW08 Use of Pedestal Grinders
 - SSW09 Working at Height
 - SSW10 Use of Mobile Elevating Work Platform (MEWP)

SSW11	Welding of Lifting Eyes
SSW12	Use of Ladders

Contents (cont.)

6.0	Safe Systems of Work (cont.)
SSW13	Use of Fork Lift Trucks (FLT)
SSW14	Use of Mechanical Band Saw
SSW15	Use of Solvents / Spraying
SSW16	Operation of Mobile Plant
SSW17	Loading / Unloading of Steel Stock / Components with FLT
SSW18	Lone Working
SSW19	Use of Hand Held Vibrating Tools
SSW20	Use of Overhead Cranes
SSW21	Use of Combination Metalworking Machines
SSW22	Use of Scaffolding / Mobile Towers
SSW23	Manoeuvring Steel Stock into Workshops
SSW24	Use of Guillotine
SSW25	Operation of Peddinghaus FPB1500 (Plasma Cutter)
SSW26	Operation of Shot Blasting Equipment
SSW27	Operation of Kaltenbach Grader Saw
SSW28	Operation of TDK 1000/3C Drilling Machine
SSW29	Operation of FDB2 (Oxy / Acetylene Cutter and Hole Drill)
SSW30	Hand Held Disc Grinding and Cutting
SSW31	Use of PPE
SSW32	Manoeuvring of Steel Stock / Components into Workshop using FLT.
SSW33	Use of Magnetic Drills
SSW34	Use of Radial Drill
SSW35	Unloading / Loading Steel Stock with Overhead Crane
SSW36	Use of Trestles and Stands
7.0	Applicable Principal Legislation
8.0	Monitoring
9.0	Review

COMPANY HEALTH AND SAFETY POLICY STATEMENT

It is the policy of Henry Smith (Constructional Engineers) Ltd to do all that is reasonable to prevent personal injury and damage to property, and to protect everyone (including the public) from foreseeable work hazards in so far as they come in contact with the Company or its products. The company aims, so far as is reasonably practicable, to ensure adequate resources to provide: -

- a) Safe and healthy working conditions for all its employees;
- b) Training and instruction, where necessary, to enable employees to perform their work safely and efficiently. Specific training in accident prevention for management and supervisors so that a safe workplace is maintained.
- c) All necessary safety devices and personal protective equipment, and to supervise its use;
- d) Maintain a constant and continuing interest in health and safety matters by consulting and involving employees;
- e) Contact with relevant health and safety bodies such as the British Safety Council so that up to date knowledge on legislation, codes of practice and guidance relating to our activities is available;
- f) Procedures to ensure that work done by Henry Smith (Constructional Engineers) Ltd does not affect non-employees such as sub-contractors or visitors whilst they are on Company premises or places of work;

It is the duty of every employee: -

Under Section (7) of the Health & Safety at Work etc. Act 1974 to cooperate with the employer in meeting these statutory duties, to take reasonable care of himself and others, and to not intentionally misuse anything provided in the interests of health and safety;

and: -

Under Section 14 of the MHSW Regulations 1999 to use plant and equipment in accordance with training and information provided, informing the employer of any defects or shortcomings in plant, equipment and protection arrangements.

To be familiar with the contents of the Company Safety, Health and Environmental Policy and Procedures Manual.

and: -

Revisions will be made to this policy whenever necessary in the light of changes in legislation or incidence of accidents and ill health but in any case will be reviewed annually.

.

..... G.W. Kitching

Date: 01/01/11

Managing Director

COMPANY ENVIRONMENTAL POLICY STATEMENT

Henry Smith (Constructional Engineers) Ltd recognises that its operations have a potential to affect the environment.

The Company is committed to the development and implementation of an active and sympathetic Environmental Policy.

The aims of the policy are to: -

- Meet all legal requirements, regulations and standards and to monitor them to ensure compliance.
- Minimise environmental impact of operations as far as is practicable.
- Take appropriate opportunities to minimise waste, reusing or recycling where possible.
- Ensure environmental awareness of employees through training and adoption of sound environmental principles.
- Ensure that Environmental objectives and targets set at review meetings are monitored for continuing improvement.
- Ensure that the policy is understood and implemented throughout the company and that staff are aware of their environmental responsibilities.
- Ensure adequate training and resources are available to enable staff to discharge their responsibilities.
- Operate plant and machinery proven to be clean, well maintained and environmentally friendly and fuel efficient.
- Monitor noise levels and operate machines and equipment that minimise ambient noise levels.

..... G.W. Kitching
Managing Director

Date: 01/01/11

2.0 ORGANISATION AND RESPONSIBILITIES

The Managing Director has overall responsibility for ensuring the implementation of the Safety, Health and Environmental Policy and Procedures however, the Contracts Managers and Workshop Foreman have direct responsibility for the following matters in respect of carrying out and observing this policy and the requirements of the Health and Safety at Work etc. Act 1974. The Contract Managers and the Workshop foreman have delegated responsibilities for ensuring that: -

1. Personnel under their charge comply at all times with the requirements of current Safety, Health and Environmental legislation.
2. All personnel, for whom they are responsible, are made aware of their individual and collective responsibilities whilst at their place of work or carrying out their designated duties at a place other than their normal place of work.
3. All personnel for whom they are responsible are provided with the advice, training and information necessary to fulfil their responsibilities.
4. Periodic documented checks are carried out to monitor safe practice and the compliance with procedures in accordance with the Company's Safety, Health and Environmental Policies.
5. Adequate resources are available to rectify non compliance that may exist and to secure continued improvements in safety, health and welfare arrangements provided.
6. Appropriate records are kept and registers maintained in respect of statutory requirements relating to employees accidents and reports under the Health and Safety at Work etc. Act 1974. The Company Policy, Periodic Safety Checks/ Inspection and details of work completed to eradicate hazards to the health and safety of employees.

The Company has delegated certain responsibilities to named staff for the carrying out of specific tasks and areas of work within the Company (See Responsibility Chart for details).

Any query by personnel on Safety, Health and Environmental matters should be referred to the relevant manager.

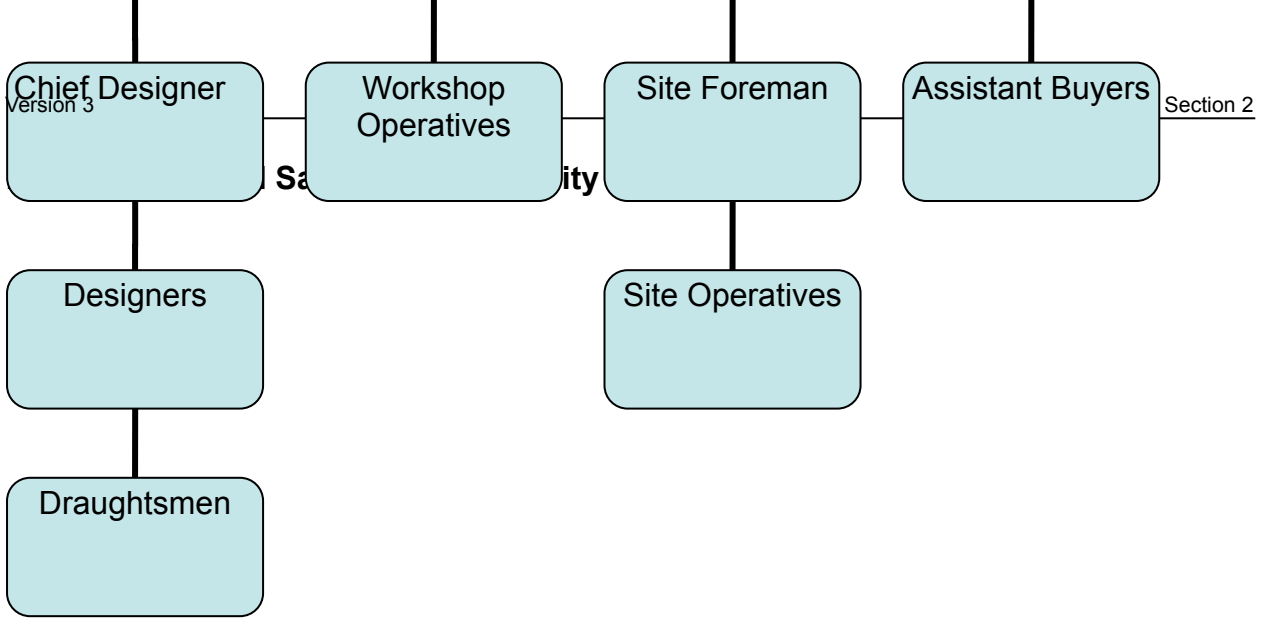

2.2 DUTIES

Responsibility for the implementation of the Company's Health and Safety Policy follows the formal delegation structure of the Company.

MANAGING DIRECTOR

Will: -

1. Ensure the Company's Health and Safety Policy and Procedures are regularly reviewed and audited in accordance with changes in regulations, working practices, management structure etc.
2. Ensure the findings of all inspection reports, insurer's reports, safety consultant advice etc. are acted upon to ensure safe working conditions and practice for all employees.
3. Ensure all documentation relating to accidents, young persons, reportable disease, statutory inspections, insurances, maintenance records etc. are maintained through the Company Secretary.
4. Provide adequate resources to ensure compliance with the Company's Health and Safety Policy can be achieved.
5. Monitor the effectiveness of the Health and Safety Policy and to make arrangements as follows: -
 - Documentation of risk assessments with findings brought to the attention of all employees
 - Provision of safety consultation from / with employees
 - Assessment, implementation and maintenance of safe workplace arrangements in regard to vehicles and employees
 - Ensuring effective machine maintenance and repair of all work equipment including hand tools
 - Assessing the risk from hazardous substances and bringing the findings to the attention of all employees
 - Ensuring adequate supervision of young workers, trainees, apprentices etc.
 - Provision of suitable and sufficient training in health and safety matters for all employees
 - For the investigation of all accidents and reporting to the HSE where appropriate.
 - For ensuring fire risk assessments are carried out and the necessary control measures are implemented.
 - For provision of adequate welfare facilities and to regularly monitor standards of cleanliness and hygiene taking appropriate action where necessary.
 - Ensuring the provision of appropriate PPE
 - Ensuring manual handling tasks are assessed, reducing wherever reasonably practicable and providing mechanical assistance where possible.

ADMINISTRATION SUPPORT

Will: -

Undertake administrative duties in regard to the keeping of all records appertaining to health and safety and assist the Managing Director to record management of inspections, insurances, training, audits etc.

COMPANY SAFETY CONSULTANT

The Safety Consultant, upon request

Will: -

- Review and audit the existing policies and procedures manual
- Advise on specific matters / problems
- Audit the premises and work practices at site
- Provide and organise safety training
- Advise on legislative changes
- Carry out risk assessments and provide documented safe systems of work where necessary

WORKSHOP FOREMAN

Will: -

- Understand the Company Policy and Procedures for Health, Safety and the Environment and ensure that they are brought to the notice of all employees, particularly new starters. Ensure all work is carried out in accordance with its requirements and bring to the notice of the Managing Director any improvements or additions which are deemed necessary.
- Set a personal example to all operatives and take reasonable care for the health and safety of himself and others affected by his actions.
- Provide effective supervision to all operations and ensure the company safe working procedures requirements for use of PPE etc. are followed
- Ensure young persons (16 – 18 years) are effectively supervised.
- Cooperate with the company on all matters relating to health and safety
- Ensure all plant and work equipment is used properly and for the purpose it was intended and NOT used if defective
- Ensure regular inspection and maintenance of plant and equipment and bring any significant defects to the attention of the Managing Director.
- Report all accidents or incidents however minor to the Managing Director immediately, maintain the accident book and undertake accident investigation.
- Maintain good housekeeping practices
- Ensure all plant and equipment is use with its safety features operational, e.g. interlocks, guarding etc.
- Ensure all operatives know what to do in the case of fire or emergency (including display of appropriate notices).
- Ensure all deliveries are safely loaded / unloaded.
- Keep employee training records
- Ensure PPE issue is recorded
- Maintain a COSHH register
- Ensure fire risk assessments are undertaken and control measures implemented.
- Ensure effective signage around the works (including display of Health and Safety Law posters).
- Induct, supervise and issue visiting contractors with the relevant safe working procedures.

CONTRACTS MANAGER

Will: -

- Understand the Company Policy and Procedures for Safety, Health and the Environment and ensure that they are brought to the notice of all employees, particularly new starters. Ensure all work is carried out in accordance with its requirements and bring to the notice of the Managing Director any improvements or additions which are deemed necessary.
- Organise sites so that work is carried out to the required Safety, Health and Environmental standards with the minimum risk to employees, other contractors, the public, equipment or materials.
- Where necessary, issue written instructions, risk assessments and method of work. Check that any Sub-contractors engaged are working in accordance with their agreed Method Statements and risk assessments and are familiar with the Company policy and procedural arrangements for Safety, Health and the Environment.
- Ensure that all relevant registers, records and reports are up to date and properly filled in and ensure that they are kept in a safe place. Ensure that any statutory notices are prominently displayed.
- Ensure that the Site Foremen and personnel under their control are aware of their responsibilities for safe working.
- Ensure that all personnel are fully trained for their role, certificated for the plant they drive and hold a VALID licence.
- Ensure all Sites are risk assessed and monitored.
- Ensure that all information available relating to underground services on the site is obtained and that relevant services are located, marked and plotted accurately on the ground before erection work starts.
- Ensure that regular documented safety inspections are undertaken at site.
- Ensure that adequate resources are made available to fully implement the policy and procedures.
- Ensure that adequate resources are provided for all plant, equipment and machinery to be maintained in a safe condition.
- Ensure that accidents and incidents are notified to the Health and Safety Consultant and the Managing Director are investigated and reported and all documentation completed. Take appropriate corrective action to prevent a recurrence.

- Set a personal example by wearing the required protective clothing and by actively encouraging a positive attitude towards Health and Safety by those employees under their control.

SITE FOREMAN

Will: -

- Understand and effectively implement and promote the Company Policy and Procedures for Safety, Health and the Environment.
- Ensure that all persons under their control, including subcontractors, are fully aware of any hazards present and undertake a client site induction.
- Ensure that all employees under their control know what to do in the case of fire.
- Ensure that all employees under their control know the whereabouts of First Aid facilities at work.
- Assist in the development of safe practices and systems of work to ensure the health and safety for all people under their supervision.
- Ensure that adequate supervision is provided at all times particularly to young or inexperienced workers.
- Conduct themselves in a manner which sets a good example to those under their control in all matters relating to Health and Safety, particularly regarding the wearing and use of PPE.
- Ensure that all Safety, Health and Environmental Policies are observed and that protective equipment is worn or used where appropriate.
- Ensure that all safety devices and guards are always fitted, properly adjusted and maintained adequately.
- Ensure that all machinery and equipment is properly maintained and safe to use.
- Ensure that all defects in their workplace are reported and rectified.
- Maintain good housekeeping within the area under their control at all times.
- Seriously consider any suggestion or requests regarding health and safety from anyone under their control.
- Liaise with the Contracts Manager, Managing Director and Company Safety Consultant on all matters concerning health and safety.
- Bring to the Contract Manager and Managing Director's attention anything which will, or may, create a health or safety hazard on site.
- Ensure that employees who do not follow relevant rules, procedures, systems of work etc. are clearly instructed as to what they should do.
- Bring to the attention of the Contracts Manager and Managing Director those employees under their control who fail to carry out their responsibilities under the

Safety, Health and Environmental Policy, local rules, procedures or systems of work etc.

WORKSHOP / SITE OPERATIVES

Will: -

- Read and understand the company's safety and health policy and procedures manual and work in accordance with the requirements.
- When working on client sites ensure the client's rules are known and adhered to
- Take reasonable care for the health and safety of themselves and others affected by their actions
- Cooperate with the company on all matters relating to health and safety
- Use all plant and equipment for its intended purpose only and in accordance with the manufacturer's instructions and training
- Inspect plant and equipment before use, and not use defective or unguarded equipment.
- Report all defects immediately
- Not operate equipment for which they are not authorised
- Wear the PPE required for the work. Ensure the COSHH register is consulted for specific requirements in regard to the use of hazardous substances.
- Maintain good housekeeping practices
- Be familiar with relevant emergency procedures
- Report all accidents or incidents immediately however minor.
- Cooperate fully with any accident investigation.

TECHNICAL DIRECTOR

Will: -

- Ensure the design department is compliant with the Company Health and Safety Policy and Procedures Manual.
- Ensure all personnel in the design team are suitably qualified and experienced to undertake their health and safety duties
- Ensure clients are advised of their duties under CDM Regulations before work commences
- Ensure the design team has sufficient competence and resources to undertake their duties under CDM Regulations.
- Ensure design personnel are provided with construction health and safety training with particular reference to the CDM Regulations and key site hazards.

CHIEF DESIGNER

Will: -

- Ensure the design team is aware of their responsibilities under the Company Health and Safety Policy and Procedures Manual and under CDM regulations
- Ensure all design personnel have access to up to date Health and Safety information
- Ensure an adequate technical library is maintained
- Ensure an effective document control system is followed
- Ensure clear and effective arrangements for design coordination, planning and change making.
- Ensure cooperation with other design organisations involved in a given project
- Ensure records of crucial health and safety decisions are kept
- Ensure the design risk assessment process is effectively carried out in applying the principles of prevention and protection
- Ensure health and safety is part of the design review process from early stages through to completion
- Ensure industry good practice, legislative change, new products and materials are brought to the attention of the design team.

DESIGNERS

Will: -

- Be familiar with relevant aspects of the company Health and Safety Policy Manual
- Prepare designs with adequate regard to health and safety and to the information supplied by the Client.
- Ensure designs avoid foreseeable risks to persons carrying out construction work by: -
 - Combating risks at source
 - Giving priority to measures which protect the whole workforce rather than the individual
- Consider how foreseeable risks may be avoided
 - During maintenance
 - During subsequent refurbishment
 - Eventually when the structure is demolished
- Provide adequate information in or with the design for safe construction, e.g. erection method statements
- Co-operate with the Planning Supervisor and with any other designers to ensure compliance with the CDM Regulations.
- Provide information for the health and safety file where required.
- Keep up to date with industry good practice, legislative changes, new materials and processes etc.
- Undertake continuous personal development

DRAUGHSTMEN

Will: -

- Be familiar with relevant aspects of the Company Health and Safety Policy Manual
- Competently translate the project design information into working drawings
- Liaise with other members of the design team to bring about a competent and safe outcome
- Undertake any necessary training the company determines is appropriate to remain up to date with systems, procedures, standards and technology.
- Refer any deficiencies noted in the information to the designer
- Maintain a competent drawing register and information retrieval system
- Ensure that all relevant design and drawing information remains secure, backed up and uncorrupted
- Undertake continuous professional development

CHIEF BUYER

Will: -

- Arrange for timely relevant statutory inspections to be undertaken
- Keep records of statutory inspections (fixed and portable / mobile)
- Keep records of electrical inspections
- Ensure contractors / services purchased are aware of the relevant sections of the Company Health and Safety Policy manual
- Ensure where appropriate that all materials / goods / services and equipment purchased conform to the relevant standards and carry any necessary certification of testing, safety and quality compliance.

ASSISTANT BUYERS

Will: -

- Undertake the relevant support duties as determined by the Chief Buyer.
- Assist in the statutory record keeping process.

3.0 ARRANGEMENTS

3.1 RISK ASSESSMENT / METHOD STATEMENTS / SAFE SYSTEMS OF WORK

All work activities will be suitably and sufficiently risk assessed in accordance with the Management of Health and Safety at Work Regulations 1999.

Specific risk assessments will always be carried out under the appropriate legislation for: -

- Manual handling tasks
- Use of VDU equipment
- Work involving hazardous substances
- Work involving young persons and pregnant women
- Work in confined spaces (none identified)
- Work at Height
- Fire Hazards
- Exposure to Noise and Vibration
- First Aid provision

The risk assessments will be undertaken by the Contracts / Workshop Foreman assisted by the Company Safety Consultant where required and the findings documented and brought to the attention of employees, contractors, self employed persons and all persons not employed by the Company who may be affected by the undertaking by the respective line managers.

Implementation of the risk control methods, method statements and safe systems of work identified by risk assessment will be the responsibility of the foreman supervising the work.

A number of generic risk assessments have been undertaken by the Company and all employees are familiar and trained in compliance with the control measures and safe systems of work identified.

Assessments will be reviewed annually or when the work activity changes or there is a change in legislation whichever is sooner.

It will be the responsibility of all employees to conduct themselves in an appropriate manner to ensure their own health and safety and that of all others affected by their actions. No safety device, safe system of working or procedure shall be compromised. All aspects of the company's policies and procedures shall be adhered to.

3.2 CONSULTATION WITH EMPLOYEES

Employees will be consulted on health and safety matters in accordance with the Health and Safety (Consultation with Employees) Regulations 1996 in regard to:-

- Any change which will substantially affect their health and safety at work.
- The information required by employees on the likely risks and dangers arising from their work and the measures to reduce such risks.
- The planning of health and safety training.

Consultation with employees will be provided by the Company Director(s) assisted by line managers and the Company Safety Consultant.

The consultation arrangements will include: -

- The appointment of safety representatives from relevant disciplines who will attend safety committee meetings
- Toolbox talks with feedback sessions

The safety committee will convene quarterly and be chaired by the Managing Director. The Agenda will include: -

- Site Operations Report
- Workshop Operation Report
- Accident / Incident Review
- Inspection / Audit Reports
- Legislation Updates
- Training Reviews
- Initiatives / Best Practice

Workshop Safety Representative: P. Gobbett

3.3 WORKPLACE / VISITORS / INDUCTION

3.3.1 Company Offices, Workshops and Compound

The workplace will be assessed to ensure people, vehicles and equipment can operate safely in accordance with the Workplace (Health, Safety and Welfare) Regulations 1992.

The assessment will address primarily: -

- Pedestrian segregation and walkways
- Signage
- Lighting
- Layout
- Vehicle operation
- Building maintenance including ventilation, temperature and welfare
- Access and Egress
- Fire

The Workshop Foreman assisted by the Company Safety Consultant will be responsible for the assessment and maintenance of such measures in and around the works. The Company Secretary will be responsible for the offices.

The Managing Director will be responsible for the implementation of all assessment requirements.

3.3.2 Security Measures

Security of the Offices, Workshop and compound is the responsibility of the Managing Director. Designated personnel are responsible for key security and lock up procedures.

The Managing Director will ensure that unauthorised entry and trespass onto the company premises is discouraged by the siting of appropriate barriers, fences and locked gates and warning signs. The premises are protected by CCTV cameras and an intruder alarm system (office) all of which are maintained.

Materials and equipment will be stored in a safe and tidy manner so as not to present a hazard, i.e. overbalancing, trip etc. to workforce and visitors alike.

It will be the responsibility of the Managing Director to ensure overall compliance.

Responsibility for security at site generally rests with the Client, however the Contractor Managers will ensure that all Company and Contractor plant and equipment remains secure at shift end in as far as is practicable to do so.

.3 Visitors

Visitors to the premises will be required to sign in and out, wear the appropriate PPE and will be supervised throughout the duration of their visit by an appropriate person.

Visitors will be shown the appropriate rules by the person on the reception at the time, these will include: -

- a) Accident and Emergency Procedures
- b) Fire Evacuation Procedures

Additionally for visitors / contractors to the yard / workshops

- c) Workshop Rules

.4 Induction

New staff inductions will be undertaken by appropriate line managers.

- 1) Site Based – Contracts Manager
- 2) Workshop Based – Workshop Foreman
- 3) Office Based – Head of Department

Site / Offices / Works induction will include: -

- Site / Yard / Office familiarisation
- Evacuation procedure, including fire exits / routes
- Accident Reporting Procedure
- First Aiders and Equipment location
- Specific hazards

An induction form will be completed and placed on the employees file by the inductor.

Where contractors are required to undertake work within the workshops, offices or compound a safety induction will be given by the Works Foreman and a permit to work issued by the Workshop Foreman or other appropriate person. A record of the induction will be kept.

The Contracts Managers will be responsible for ensuring all site based personnel including contractors and agency workers receive a Client induction and a relevant Company induction to include site operational procedures.

3.4 VEHICLES, PLANT AND EQUIPMENT

All work equipment will be provided and used in accordance with the Provision and Use of Work Equipment Regulations 1998 (PUWER) (as amended).

The Workshop Foreman will be responsible for inspection and identification of all equipment and plant requiring maintenance and repair at the workshop site and for reporting problems to the Managing Director.

The Contracts Managers are responsible for inspection, security and identification of all vehicles, plant and equipment used on site.

The Managing Director will be responsible for ensuring effective inspection and maintenance procedures are drafted and implemented and for implementing the statutory inspection, maintenance and repairs identified.

The Managing Director assisted by the relevant Manager will check and ensure all new and second hand tools, equipment, vehicles and hired in plant meets health and safety standards prior to its use.

All machinery and equipment used will be adequately maintained in safe working order. The Managing Director, assisted by the relevant Managers will ensure all necessary statutory examinations are carried out. Valid certificates are available upon request. Equipment will not be used or worked upon unless it is safe, correctly guarded, immobilised and with properly operating safety devices.

Statutory Inspection Schedule: -

- Lifting equipment 12 monthly
- Lifting accessories (inc. persons) 6 monthly
- LEV equipment 12 monthly
- Pressure systems 12 monthly

Non Statutory Inspection Schedule: -

- Portable electrical equipment 6 monthly
- Fire extinguishers 12 monthly
- Fixed electrical installations
 - Insurance requirements

3.5 HAZARDOUS SUBSTANCES

Risks arising from the use of all substances hazardous to health will be assessed as required by the Control of Substances Hazardous to Health (amendment) Regulations 2004 (COSHH).

The Workshop Foreman assisted where required by the Company Safety Consultant is responsible for the undertaking of such assessments, contacting manufacturers and suppliers of all substances to gain the required information.

Employees and any non employees who are at risk from exposure will be informed of the findings and shall be given training to comply with the necessary actions required to limit exposure.

Work with asbestos may only be carried out by a Contractor licensed under the Asbestos (Licensing) Regulations.

The Workshop Foreman and Site foreman will be responsible for ensuring the designated controls are implemented.

The Workshop foreman will check that new substances purchased can be used safely before issue. No product shall be used without prior consultation of the COSHH file and strict adherence to the procedures for use contained therein.

The Company Safety Consultant will review assessments annually or upon change of legislation or work practices whichever is the sooner.

Information relevant to such hazardous substances with regard to the potential impact on others will be provided to the client at site as required.

3.6 INFORMATION, INSTRUCTION AND SUPERVISION

All employees, particularly new starters, are provided with comprehensive and relevant information on the risks to their health and safety as identified by the assessment process in accordance with the Management of Health and Safety at Work Regulations 1999 (MHSWR).

The Contract Managers and Workshop Foreman will ensure all employees are given a Company induction prior to starting work and are familiarised with all relevant information contained in the Company Safety, Health and Environmental Policy and Procedures Manual.

Health and Safety advice is available from the relevant line Manager supported by the Company Safety Consultant where necessary.

Supervision of young workers / trainees / new starters is the responsibility of the workshop foreman and site foreman where appropriate.

The Contract Managers are responsible for ensuring all site personnel under their control are routinely appraised of safety issues through the conducting of regular tool box talks.

It is the responsibility of all employees, contractors and agency workers through the site foreman or Contract Managers working at client locations and sites to gain a safety induction which details the necessary information required to carry out the work in safety. This information is to include any exposure to hazardous substances.

3.7 COMPETENCY AND TRAINING

- 3.7.1 Induction training and job specific training, including environmental awareness training, will be identified by line managers and provision arranged for all employees by the relevant line manager assisted by the Company Safety Consultant where necessary. Training requirements are to be regularly reviewed.

It is the responsibility of all employees whilst at work to take reasonable care for the health and safety of himself and others who may be affected by his work in accordance with the Health and Safety at Work etc. Act 1974 (HSWA 1974).

All employees are trained and competent to carry out their designated duties.

No employee is authorised to undertake tasks, use equipment, drive vehicles etc. unless he has been specifically trained and authorised to do so.

It is expressly forbidden for any employee to operate plant and equipment unless he has received adequate training and is holding a current licence (where appropriate) or certificate of competency.

In the case of Fork Lift Truck operator's assessment, refresher and remedial training will be provided every three years.

The Contracts Manager / Workshop Foreman will identify shortfalls in personnel competency and ensure the necessary training is undertaken.

Employees are required to attend all safety and refresher courses arranged on their behalf.

- .2 The Company will make appropriate checks in regard to employment of migrant workers to ensure they possess adequate English speaking skills and comprehension. The Company will endeavour, through an interpreter or translated material, to inform the migrant worker of relevant risks to health and safety, safe working practice, first aid arrangements and emergency procedures.

3.8 ACCIDENT REPORTING, FIRST AID AND WORK RELATED ILL HEALTH

3.8.1 Accident Reporting

It is the responsibility of all employees to report accidents, incidents, injuries, diseases and dangerous occurrences including work related health conditions, e.g. vibration white finger, immediately upon occurrence or discovery.

All employees are familiar with the published accident reporting procedure.

It is the responsibility of the employee who has had the accident to ensure the accident book including any relevant site accident book is completed immediately and that the relevant Contract Manager / Workshop Foreman are informed.

The Company accident book must also be completed by the injured party at the time of or as soon as is reasonably practicable after the accident or incident occurs.

The Managing Director is responsible for informing the Health and Safety Executive via the appropriate form/procedure, under the Reporting of Injuries, Diseases and Dangerous Occurrences Regulations 1995 (RIDDOR).

Where the accident / incident is fatal / major / dangerous occurrence the foreman must ensure that the area is safe and cordoned off to enable the accident to be fully investigated.

The relevant Contract Manager is responsible for ensuring all site based accidents / incidents are reported and a record made which is to include those involving employees, subcontractors or agency workers.

3.8.2 First Aid

The Managing Director is responsible for ensuring the Company has an appropriate number of trained first aiders who attend regular refresher courses. If no first aider is available the emergency services will be called to deal with the injury.

First aid equipment is kept in the reception. It is the responsibility of the delegated first aider to ensure first aid equipment is suitable, sufficient and in date.

Employees and subcontractors are familiarised with first aid arrangements at the client's site(s) via the safety induction process.

3.8.3 Work Related Ill Health

The Company will ensure all employees are provided with such health surveillance as is appropriate having regard to risks identified by assessment. The following activities have been identified as carrying a potential risk: -

- 1) Paint spraying utilising solvents
- 2) Working with noisy machinery, e.g. use of angle grinders

- 3) Using hand held vibrating equipment.
- 4) Welding

The Managing Director is responsible for informing the HSE in the event of discovery of any occupational disease specified in RIDDOR.

Any permanent medical condition requiring drugs or otherwise, e.g. Diabetes, colour blindness, allergies, deafness, monocolour vision etc., should be declared on the Company Pre-employment screening questionnaire.

In the event of an accident / illness occurring through work the Company will assess the employees subsequent compatibility and ability to undertake their designated duties in safety.

The company prohibits all its employees and subcontractors from working under the influence of drugs or alcohol or driving vehicles belonging to the company.

Where an employee or subcontractor is required to take prescription drugs, this should be brought to the attention of the relevant line or Contract Manager.

All employees will refrain from smoking on Company and Client premises and in all company vehicles. Smoking may only be undertaken in a designated area.

Accident Reporting Procedure

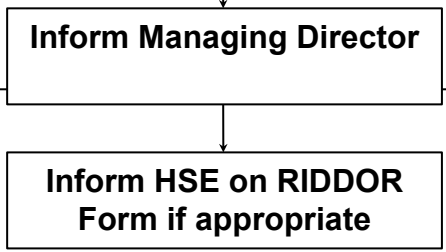

Emergency Contact Numbers: -

Office 01606 592121
G.W. Kitching 01606 595800
07974 357636

Site: -

Peter Woolley 07977 470693
Andrew Williamson 07971 203132

First Aiders

M. Lea - Works
A. Lea - Works

3.9 MONITORING, REVIEW AND AUDIT

Regular monitoring, review and audit of procedural compliance will be carried out by the Company Insurers and Company Safety Consultant.

Weekly inspections will be carried out by the Works Foreman.

Annual Policy and Procedures reviews will be carried out by the Company Health and Safety Consultant when required unless significant legislative changes occur sooner.

The Contracts Managers / Workshop Foreman will carry out all accident investigations assisted by the Company Safety Consultant where appropriate and cooperate with client site management where necessary.

The Managing Director will investigate any work related causes of sickness and absence.

All employees are required to cooperate with management in the investigation and subsequent implementation of the findings and recommendations arising from accident investigation, safety audits etc.

Monthly workplace inspections will be carried out by Contracts Managers and Workshop Safety Representatives. The Workshop Foreman will retain the reports for reference and correction of problems.

It is the responsibility of all employees to report potential defects / faults on the Defect Report form. The Workshop Foreman will retain the reports for reference and correction of problems.

Quarterly site audits will be undertaken by the Company Safety Consultant.

3.10 EMERGENCY PROCEDURES

3.10.1 Fire (Headquarters)

The Managing Director will be responsible for ensuring fire risk assessments are carried out and the necessary control measures implemented.

The nominated fire marshal(s) for the office and works will complete regular documented inspections checking fire extinguishers, escape routes etc.

The Chief Buyer will ensure that all fire extinguishers are provided, tested and maintained at the appropriate intervals.

Regular alarm testing shall be carried out along with the emergency evacuation procedure (in both daylight and dark) every 6 months. Emergency lighting where installed will be tested every 6 months. All testing of equipment and procedures will be documented and reviewed. The Managing Director will be responsible for this.

It is the responsibility of all employees to carry out hot working in a safe manner and to maintain their immediate workplace in a clean and tidy manner, free from litter, combustible materials and sources of ignition.

If you discover a fire: -

- Inform the office fire marshal / workshop foreman who will: -
 - Raise the alarm
 - Call the emergency services
 - Evacuate to the designated muster point
 - Carry out a roll call

Do not attempt to fight the fire unless it is: -

1. minor
 2. you have been trained to use an extinguisher
- Proceed to the muster point

Always ensure you have a means of escape. The office fire marshal / workshop foreman will ensure that the source of the fire is made safe whenever possible (safe to do so) by turning off fuel / electricity etc. and will carry out the head count at the muster point ensuring that all premises are evacuated including any visitors. The fire marshals will if safe to do so collect the clocking in cards and signing in book to assist in the head count.

3.10.2 Fire (Site)

The Contract Managers are responsible for ensuring the site emergency fire procedures are known to all employees, contractors and agency workers through the site induction process.

.3 Environmental

The environmental emergency procedure applies to: -

- Spillages of fuel, oils and chemicals to unmade ground or water courses
- Containment of fire water
- Emergency emptying of fuel tanks, e.g. fire, vandalism.

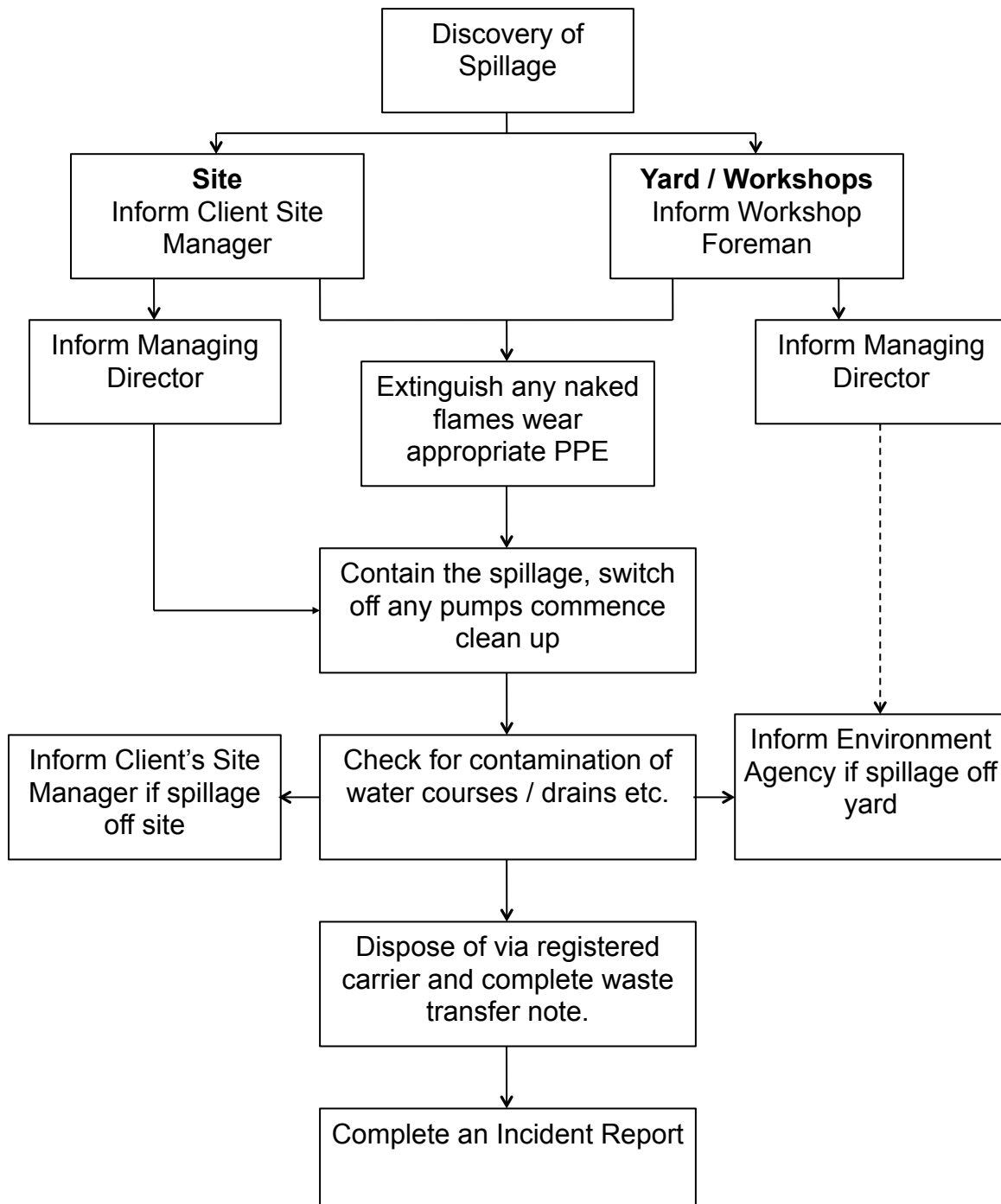

.11 WELFARE AND HYGIENE

Every workplace including the furniture, furnishings and fittings will be kept sufficiently clean and free from offensive waste matters or discharges. This will be the responsibility of the Workshop Foreman / Chief Buyer as appropriate.

Suitable and sufficient sanitary conveniences and washing facilities will also be maintained including an adequate supply of wholesome drinking water.

Maintaining a clean and tidy workplace will be the responsibility of all employees however ultimate responsibility for cleaning rests with the Managing Director

Where personnel are engaged on site working, agreement to use the clients messing and toilet facilities will be gained by the Contracts Manager. These will normally be provided by the Principal Contractor. Personnel will refrain from smoking at clients premises except in areas designated for such purpose.

It is the responsibility of all employees to ensure a good standard of hygiene, and the wearing of appropriate personal protective equipment (PPE) including gloves and barrier creams with regular cleaning of overalls. Hands should be washed regularly before taking any food, drink or cigarettes.

Minor cuts and grazes should always be cleaned and dressed particularly where waste, water and potential rat infested environments are prevalent.

Weil's disease is a serious, sometimes fatal, infection transmitted by contact with urine from infected rats. If a flu like illness is contracted immediately after working near water employees should consult a doctor immediately and notify the Managing Director.

Workshop Foremen will regularly monitor standards of cleanliness and hygiene taking appropriate action where necessary.

.12 CONSTRUCTION (DESIGN AND MANAGEMENT) REGULATIONS 2007

3.12.1 Designer Duties

Where the Company undertakes Design Duties for a Client the Company will through the Technical Director / Chief Designer: -

- Take reasonable steps to ensure the Client is aware of his duties under CDM before starting design work.
- Prepare designs with adequate regard to health and safety and to the information supplied by the Client.
- Provide adequate information in or with the design for safe construction.
- Co-operate with the CDM Co-ordinator and with any other designers to ensure compliance with their duties under the regulations.
- Provide information needed for the health and safety file.

.12.3 Contractor Duties

Where the Company is to work as a Contractor under the Principal Contractor the Company's primary responsibility is to cooperate with the Principal Contractor. The Company will through the Contracts Manager: -

- Comply with the Principal Contractor's instructions and with the requirements of the construction phase plan.
- Cooperate with the Principal Contractor and coordinate its activities with all contractors who may be affected by the company's operations.
- Provide the Principal Contractor and other contractors with assessments of risks, hazardous substances, noise and any other information concerning its activities that may have an effect on their operations.
- Provide the Principal Contractor with any information required by the CDM Co-ordinator for inclusion in the Health and Safety file.

.13 CONTRACTORS AND SUB-CONTRACTORS

3.13.1 The Contracts Manager will ensure all contractors, self employed personnel and agency workers used by the Company for site work have the necessary knowledge, experience and competency to undertake the work.

All contractors will be required to: -

- Comply with the Company Safety, Health and Environmental Policy and Procedures and all statutory legislation.
- Provide appropriate, relevant documentation for the work including risk assessments, method statements, proof of competency, insurances etc.
- Cooperate with the Company and the Principal Contractor and co-ordinate its activities with all other contractors who may be affected by its operations and activities at site.

The Contracts Manager will ensure that contractors do not utilise subcontractors without permission and that the relevant competencies, insurances, risk assessments etc. are satisfactory and approved.

.13.3 The Workshop Foreman will ensure that all contractors attending the workshops are given a suitable safety induction and that a permit to work is issued where necessary. The Workshop Foreman shall ensure that competency cards are checked before allowing work to commence.

4.0 RISK ASSESSMENT

4.1 The generic risk assessments included in the Appendices are intended to provide information in regard to control of the associated risks for all common and routine tasks.

Where tasks are particularly complex or involve a number of activities and personnel are not familiar with the operations involved a specific risk assessment with accompanying method statement must be completed.

All activities deemed to be high risk shall be specifically risk assessed. The generic risk assessments should not be relied upon.

All personnel shall familiarise themselves with the method and risk controls to be followed before attempting **any** activity.

Remember if the job conditions change significantly the activity should be ceased and a reassessment of any new risks identified be undertaken.

Assessments are completed using the following methodology: -

Severity		Likelihood	
HIGH Major Injury	3	Likely	3
MEDIUM Reportable Injury	2	Possible	2
LOW Slight Injury	1	Improbable	1

Likelihood		1	2	3
Severity	3	M	H	H
	2	L	M	H
	1	L	L	M

Risk

Rating Code R = Severity x Likelihood

A residual Risk Rating Code of: -

- 1 – 2 (low) - acceptable
- 3 – 4 (medium) - acceptable but aim to reduce if possible
- 6 – 9 (high) - MUST be reduced NOT ACCEPTABLE

A residual risk rating code of 6 – 9 requires the introduction of further control measures (where practicable) and a reassessment of the risk involved.

4.2 The following activities have been risk assessed and are held in the company risk assessment file: -

RA No.	Description	Area	Date	Review Date
S1	Use of Mobile Cranes	Site	01/01/11	01/01/12
S2	Hot Working (general)	Site	01/01/11	01/01/12
S3	Working at Height	Site	01/01/11	01/01/12
S4	Use of MEWP	Site	01/01/11	01/01/12
S5	Use of Scaffolding / towers	Site	01/01/11	01/01/12
S6	Driving on Site	Site	01/01/11	01/01/12
S7	Work near Vehicular Access	Site	01/01/11	01/01/12
S8	Operation of Mobile Plant	Site	01/01/11	01/01/12
S9	Use of Portable Welding Sets	Site	01/01/11	01/01/12
S10	Use of Portable Generators	Site	01/01/11	01/01/12
S11	Concrete Drilling	Site	01/01/11	01/01/12
S12	Touch Up Painting	Site	01/01/11	01/01/12
S13	Site Drilling of Steelwork	Site	01/01/11	01/01/12
S14	Erection of Structural Steelwork	Site	01/01/11	01/01/12
S15	Erection of Floor Beams / Specialist sections	Site	01/01/11	01/01/12
W1E	Use of Mechanical Saws	Workshops	01/01/11	01/01/12
W2E	Use of Forklift trucks / Side loaders	Workshops / Site	01/01/11	01/01/12
W3E	Use of Guillotine	Workshops	01/01/11	01/01/12
W4E	Use of Angle Grinders	Workshops	01/01/11	01/01/12
W5E	Use of Overhead Cranes	Workshops	01/01/11	01/01/12
W6E	Use of Shunter	Workshops	01/01/11	01/01/12
W7E	Use of Pedestal Angle Grinder	Workshops	01/01/11	01/01/12
W8E	Use of Combination Metal Working Machine	Workshops	01/01/11	01/01/12
W9E	Operation of Peddinghaus FPB 1500	Workshops	01/01/11	01/01/12
W10E	Operation of Peddinghaus FDB 2	Workshops	01/01/11	01/01/12
W11E	Operation of Pedimat TDK 1000/3C	Workshops	01/01/11	01/01/12
W12E	Operation of Kaltenbach circular Saw	Workshops	01/01/11	01/01/12
W13E	Operation of Shot Blasting Equipment	Workshops	01/01/11	01/01/12
W14E	Use of Magnetic Lifting Devices	Workshops	01/01/11	01/01/12
W15E	Use of 1 Tonne Swing Beam Lifting Arms	Workshops	01/01/11	01/01/12
W16E	Use of Wood Working Band Saw	Workshops	01/01/11	01/01/12
W17E	Use of A Frame "Walking" Cranes	Workshops	01/01/11	01/01/12
W18E	Use of Powered Conveyor (Bay 1)	Workshops	01/01/11	01/01/12
W19E	Use of Lifter / Transfer Beds	Workshops	01/01/11	01/01/12
W20E	Use of Radial Arm Drill / Pedestal Drill	Workshops	01/01/11	01/01/12
W21E	Use of Lathe (Elec Workshop)	Workshops	01/01/11	01/01/12
W22E	Use of Saw Sharpener (Elec Workshop)	Workshops	01/01/11	01/01/12
W23T	Unloading / Loading Steel Stock (Yard)	Workshops	01/01/11	01/01/12
W24T	Manoeuvring Steel Stock / Components into Workshops using FLT	Workshops	01/01/11	01/01/12

W25T	Loading Painted / Fabricated Steel inside Workshops	Workshops	01/01/11	01/01/12
W26T	Fabricating / Welding on Trestles	Workshops	01/01/11	01/01/12
W27T	Visitors / Contractors to the Premises	Workshops	01/01/11	01/01/12
W28T	Paint Spraying / Painting (inc. RPE)	Workshops	01/01/11	01/01/12
W29T	Moving Steel from Paint Bay to Loading Bay	Workshops	01/01/11	01/01/12
W30T	Welding Shear Studs to Flanges	Workshops	01/01/11	01/01/12
W31T	Emptying of Skips / Bins	Workshops	01/01/11	01/01/12
W32T	Routine Maintenance of Workshop Machines	Workshops	01/01/11	01/01/12

RA No.	Description	Area	Date	Review Date
G1	Deliveries to the Works (general)	General	01/01/11	01/01/12
G2	Access and Egress (Works in general)	General	01/01/11	01/01/12
G3	Use of Compressed Air Tools	General	01/01/11	01/01/12
G4	Electric Arc Welding	General	01/01/11	01/01/12
G5	Working with Electricity / Electrical Appliances	General	01/01/11	01/01/12
G6	Flame cutting / Welding (oxy / fuel)	General	01/01/11	01/01/12
G7	Working on Uneven Ground / congested areas	General	01/01/11	01/01/12
G8	Plant / Equipment Isolation	General	01/01/11	01/01/12
G9	Working with Ladders / Stepladders	General	01/01/11	01/01/12
G10	Lone Working	General	01/01/11	01/01/12
G11	Lifting and Slinging (works)	General	01/01/11	01/01/12
G12	Using Manual Hand Tools	General	01/01/11	01/01/12
G13	Use of a Rotabroach / Magnetic Drill	General	01/01/11	01/01/12
G14	Manual Handling (general)	General	01/01/11	01/01/12
G15	Use of Lifting Accessories	General	01/01/11	01/01/12
G16	Use of PPE	General	01/01/11	01/01/12
G17	Use of Electrical Hand Held Tools	General	01/01/11	01/01/12
G18	Use of Display Screen Equipment (VDU)	General	01/01/11	01/01/12
G19	Use of Hot Torches / Guns for Heating Steel	General	01/01/11	01/01/12
G20	Use of Hazardous Substances	General	01/01/11	01/01/12
G21	Resetting of Overloads (Electrical Panels)	General	01/01/11	01/01/12

5.0 PROCEDURES

- 5.1 Abrasive Wheels
- 5.2 Accident / Incident Investigation
- 5.3 Asbestos
- 5.4 Burning and Welding
- 5.5 Confined Spaces
- 5.6 Control of Substances Hazardous to Health
- 5.7 Deliveries, Loading and Shunting
- 5.8 Display Screen Equipment
- 5.9 Electricity and Electrical Equipment
- 5.10 Energy and Machinery Isolation
- 5.11 Environmental Procedures
- 5.12 Erection of Structures
- 5.13 Fabrication
- 5.14 Fire Precautions
- 5.15 First Aid
- 5.16 Hand Tools
- 5.17 Height Working
- 5.18 Hot Working
- 5.19 Housekeeping
- 5.20 LPG and Oxygen
- 5.21 Lifting Operations / Equipment
- 5.22 Lone Working
- 5.23 Machine Guarding
- 5.24 Manual Handling
- 5.25 Mobile Plant
- 5.26 Noise
- 5.27 Overhead / Underground Services
- 5.28 Painting and Spraying
- 5.29 Permit to Work
- 5.30 Personal Protective Equipment (PPE)
- 5.31 Plant and Equipment
- 5.32 Pressure Systems
- 5.33 Risk Assessment
- 5.34 Safety Signs and Warning Notices
- 5.35 Scaffolding and Mobile Towers
- 5.36 Site Procedures

- 5.37 Storage and Stacking
- 5.38 Sub Contractors and Agency Workers
- 5.39 Vibration
- 5.40 Visitors
- 5.41 Weather
- 5.42 Welfare Facilities
- 5.43 Workplace Access and Egress
- 5.44 Young Persons

5.01 ABRASIVE WHEELS

- 5.01.1 No employee is permitted to mount and use an abrasive wheel unless he has been trained to do so, is competent to carry out that duty and has been specifically appointed to do so.
- 5.01.2 The Workshop Foreman shall maintain a register where the specific classes or descriptions of wheel for which the employee is appointed is shown.
- 5.01.3 A guard must be provided, be properly adjusted and kept in position at every abrasive wheel in motion, unless it is impracticable.
- 5.01.4 The Workshop Foreman is required to ensure that the appropriate abrasive wheel is fitted for the work involved.
- 5.01.5 Employees are required to use abrasive wheels in the manner in which they have been trained. A record of training is to be maintained.
- 5.01.6 Employees will be provided with adequate training, health and safety information and written instruction where appropriate.
- 5.01.7 Equipment will be maintained in good repair and inspected prior to use. All defects should be reported to the Workshop or Site Foreman. Defective equipment must NOT be used.
- 5.01.8 Suitable PPE will be worn when using abrasive wheels. This will include appropriate eye protection (Grade 1 impact goggles).
- 5.01.9 The Company will ensure the risks to employees from hand-arm vibration are adequately controlled.

5.02 ACCIDENTS / INCIDENT INVESTIGATION

5.02.1 The foreman or supervisor responsible at each work location will be responsible for the reporting of all accidents / incidents / dangerous occurrences to the Managing Director or Contract Manager who will ensure that the company accident book is completed using the instructions printed inside the front cover. A record will be made of all employee, subcontract and agency workers incidents.

5.02.2 The Contracts Manager / Workshop Foreman must also complete the Company Accident / Incident Investigation Report. These must be completed immediately the accident or incident has occurred and forwarded to the Managing Director. In the event of a HSE reportable accident the accident scene should remain undisturbed pending an enquiry.

5.02.3 The Managing Director will ultimately be responsible for ensuring the company accident book and supporting documentation is maintained and that the Health and Safety Executive have been notified of Accidents forthwith by the quickest practicable means and in accordance with paragraph 4 below.

5.02.4 The following must be reported * to the Health and Safety Executive: -

- Fatal accidents (immediately)
- Major injury (immediately)
- *² Dangerous occurrences (safety advisor will advise) (immediately)
- Accidents causing more than three days incapacity from work (within 10 days)
- Certain diseases / medical conditions (upon discovery and diagnosis)
- Hospitalisation of 24 hours or more (immediate)

The Company Safety Consultant will advise upon the type of incident which is to be reported to the HSE. Accident records must be kept for 3 years.

5.02.5 The Company Safety Consultant will subsequently review all accidents with management making recommendations with a view to preventing a recurrence.

* Specific HSE reporting forms (2508 and 2508A) are available for this purpose. These must be submitted within 10 days.

*² Relevant dangerous occurrences include: -

- Collapse of scaffolding
- Failure of a MEWP
- Partial collapse of a structure (5 tonnes of material)
- Overturning FLT / crane
- Contact with overhead power lines (>200v)

COMPANY SAFETY PROCEDURES – ACCIDENT INVESTIGATION

Definition of an Accident

An accident is an unplanned event, which results in physical harm and / or property/ environmental damage. It usually results from contact with a source of **energy**, the strength of which is above the ability of the body or structure to withstand.

Purpose

Accidents are investigated for a variety of reasons: -

- **To prevent recurrence – the objective to stop accidents of a similar nature from recurring, using the lessons learned from the original accident**
- Curiosity – why did it happen?
- Anxiety reduction – to reassure others it will not happen again or particularly to them
- To apportion blame – almost automatic reaction
- Legal requirements – a requirement of the Social Security Act to investigate accidents and to report them under RIDDOR
- In preparation for a criminal or civil law case
- Justification of expenditure by management
- Preparing a report on the accident for the company's insurance firm
- Determining the cause(s) with a view to preventing a further recurrence
- Gathering information for use in any proceedings
- Confirming or refuting claims from any source
- Preparing notifications to be made to the HSE or other enforcing agency

Prevention

From the view point of prevention, the purpose of the investigation and reporting is to establish whether recurrence can be prevented by the introduction of: -

- Safeguards
- Improved safety procedures
- Training
- Information
- Any combination of the above

Procedure

The immediate concern of the investigation will be to establish the **facts** associated with the accident. The investigation should seek to establish: -

- **What** did the person do or fail to do that contributed to the accident?
- **What** did the job or surrounding physical conditions contribute to the accident?
- Complete Accident book and accident report forms
- Complete the accident / investigation report including witness statements
- Notify the appropriate authorities

It is important that written records and statements are made in ink and pages numbered. Statements for witnesses should contain such details as age, occupation etc. The date, time and place of the interview should be indicated at the end of the statement. Witnesses' statements should be given in their own words, even if these include slang words or expletives.

Both the interviewee and the interviewer should sign statements, including any continuation sheets. All witnesses should receive a copy of their statement.

The above steps are dealt with in more detail below: -

The report format to be: -

- Summary
- Ref. No.
- Location
- Date and Time
- Accident / Incident
- Injured person
- Age and occupation
- Cause
- Injuries
- Damage
- Weather
- Events prior to accident / incident
- The accident / incident
- The investigation
- Conclusion
- Recommendations

Investigate Promptly

The sooner an investigation is started the better supported in terms of accuracy it will be. The first priority will be to establish the cause of the accident. Where HSE Inspectors may wish to investigate it is important not to disturb the scene or equipment.

Record Evidence

- Time, date and place of the accident should be recorded
- Environmental conditions should be recorded; weather, ground conditions, daylight / darkness, atmosphere and other general conditions
- Photographs should be taken to provide as much information as possible to record the state of the scene and the general conditions which existed at the time
- Time, date and place of photographing must be written on the back of each picture
- Make sketches and diagrams and indicate dimensions where appropriate

Interview Injured Person

This should be an early priority – even the briefest description of the accident will be helpful initially. The injured person should be in a fit state to answer questions. It is important to stress that the purpose of the investigation is to find the cause so that preventative action can be taken. Blame should not be apportioned. A better response will be achieved if a genuine interest in the welfare and recovery of the injured person is demonstrated.

Question the Person(s) in Charge

If you are a person in charge make a written statement yourself – the following are examples of questions to be asked: -

- What was the normal job of the injured person?
- What type of job was being performed?
- Was it planned or part of a planned activity?
- At what stage of the work did the accident occur?
- Was the person involved trained and if so, when?
- Was the person authorised to carry out that type of work / use machinery in that location?
- What instructions had been given?
- How many other persons were or should have been involved in the activity?
- Did any statutory regulations or code of practice cover the activity or task?
- Were correct / safe procedures being observed?
- What safety equipment / protection was available and in use?
- Were other contractors' employees or plant and machinery involved or at fault?
- Had the injured person been involved in previous accidents?

Interviewing Witnesses

It is important to interview witnesses as soon as possible. By definition the person having the accident is a witness. Witnesses may become unavailable or influence each other. As time elapses distortion of the facts can occur or important details may be forgotten.

Witnesses should be interviewed one at a time and a signed statement obtained (see company form).

When interviewing someone put them at ease and make sure that the facts are obtained. Make it clear that the object of the investigation is to prevent a recurrence of a similar accident, not to apportion blame.

The following examples of questions should be asked: -

- What did the witness see, hear, smell or feel?
- What was the witness doing at the time?
- What was the proximity of the witness to the accident or occurrence?
- What actions did he take?
- What actions did others take before and after the accident?
- What was the condition of the workplace at the time?
- What hazards or unsafe conditions existed? What unsafe acts were performed?
- What was the probable cause(s) of the accident or occurrence?

It is expected that certain details will differ in witnesses' accounts but there should be agreement about basic facts if the true cause of the accident is to be determined.

Inspect Plant / Equipment for Misuse or Defects

Inspect the plant or equipment as soon as possible after the accident and note any signs of misuse or defects which may or may not have contributed to the accident. Persons more familiar with the plant or equipment may be able to provide valuable information.

Establish Sequence of Events

By collating all the evidence and information it should be possible to establish a sequence of events leading up to the accident.

Ascertain the Extent of Injury or Damage

It may not be possible to ascertain the full extent of injuries but an assessment may be helpful. It is easier to describe the damage and a comprehensive record should be made.

5.03 ASBESTOS

5.03.1 The company will assess the risks of exposure to asbestos at the company premises and: -

- Complete a survey and sampling exercise to determine location
- Keep an up to date location plan
- Ensure that all asbestos materials are suitably signed (low risk)
- Remove all asbestos materials as necessary (high risk)
- Provide relevant information to all employees and building / maintenance contractors who are likely to disturb it.

5.03.2 The Company will produce a management plan to identify, assess and prevent or reduce asbestos exposure and spread.

5.03.3 The Company will review the plan annually and take necessary steps to put the plan into action.

5.03.4 The Company will ensure any work with asbestos is carried out by a licensed company.

5.03.5 The Company will ensure all asbestos waste is disposed of in accordance with appropriate legislation.

5.03.6 No one within the company is permitted to carry out any work involving asbestos.

5.04 BURNING AND WELDING

- 5.04.1 All personnel will be competent, trained and authorised to undertake burning and welding and any associated hot work, e.g. angle grinding.
- 5.04.2 On a client site a permit to work and specific authorisation may be required.
- 5.04.3 All personnel will wear suitable PPE including gauntlets, fire retardant overalls and face shield and RPE in addition to steel toe cap safety boots and ear protection.
- 5.04.4 All equipment will be inspected prior to use. Defective equipment will be taken out of use and reported to the foreman in charge.
- 5.04.5 The Company Hot Working procedures and Fire Precautions will be followed.
- 5.04.6 The use of Electric Welding / Flame Cutting equipment will be carried out in accordance with the relevant HSE Guidance Notes.

5.05 CONFINED SPACES

- 5.05.1 The foreman of the site is required to ensure that no employee, self employed person or Contractor working for the company enters a confined space* without permission.
- 5.05.2 The foreman should inform the Contracts Manager of an intention to permit working in a confined space, prior to the work taking place.
- 5.05.3 The Company will ensure that employees are trained, instructed and supervised in all tasks involving confined spaces.
- 5.05.4 The Company will ensure that no work will be carried out in a confined space unless there is a written safe system of work in place, suitable and maintained equipment available along with emergency arrangements for the rescue of persons, including the provision and maintenance of resuscitation equipment and a suitable unobstructed means of access.
- 5.05.5 The Company will ensure that confined space working is not undertaken if it is reasonably practicable to carry the work out in any other way.

* Any chamber, tank, vat, silo, pit, trench, pipe, sewer, flue, well and other similar confined space where there is a risk of: -

- Serious injury from fire or explosion
- Increase in body temperature which may result in unconsciousness
- Unconsciousness or asphyxiation resulting from exposure to gas, fume, vapour or lack of oxygen.
- Drowning from rising liquid level.
- Asphyxiation / entrapment by a free flowing solid, i.e. sand etc.

5.06 CONTROL OF SUBSTANCES HAZARDOUS TO HEALTH

- 5.06.1 The Company will ensure a register of substances is maintained by the Workshop Foreman assisted by the Company Safety Consultant where necessary.
- 5.06.2 The Company Safety Consultant, where required, will carry out an assessment of all substances* to be used to determine which of those substances are hazardous to health and advise appropriate control measures.
- 5.06.3 The Company will ensure all employees and self employed persons working for the company are suitably trained in their use and familiarised with the control measures required.
- 5.06.4 The Company will undertake periodic monitoring at the workshops to determine employees exposure to solvents etc.
- 5.06.5 All chemicals will be **securely** stored in an appropriate container / cupboard with adequate ventilation and suitable warning signage.
- 5.06.6 A specific risk assessment will be undertaken where employees are required to work with hazardous substances in confined spaces.
- 5.06.7 The appropriate protective measures determined from the COSHH assessment will be maintained and provided by the Company, i.e. barrier creams, masks, gloves, goggles etc.
- 5.06.8 Appropriate first aid measures will be maintained including eye wash stations.
- 5.06.9 The Company will exchange substances for less hazardous ones whenever practicable and whenever residual risk cannot be effectively controlled.
- 5.06.10 Where substances are deemed to be flammable these will be exchanged for less flammable products where practicable, stored separately from other substances and a no naked flames policy will be enforced.
- 5.06.11 Surplus hazardous substances, contaminated rags, packaging, clothing etc. will be disposed of in accordance with the Company Environmental procedures.

* substances that are capable of causing adverse health effects and include chemicals, biological agents, carcinogens, dusts, allergens etc.

5.07 DELIVERIES, LOADING AND SHUNTING

5.07.1 The Company foreman will ensure that all steel deliveries are safely unloaded and stacked in a safe manner.

5.07.2 The Company Foreman will ensure that all visiting lorry drivers adhere to site and yard rules at all times.

5.07.3 The Company Foreman will ensure that where lorries carrying steel components are stacked in an unsafe manner that no attempt is made to unload unless / until appropriate equipment is available.

5.07.4 The Company Foreman will ensure that personnel loading steel components to lorries follow company safe work procedures at all times.

5.07.5 All personnel involved in loading lorries will ensure that they do not place themselves at risk from falling or from falling materials.

5.07.6 Where loaded trailers are moved around the yard by shunter the Foreman will ensure that the shunter is fit for purpose and operated by trained, competent and authorised personnel only.

5.08 DISPLAY SCREEN EQUIPMENT (VDU's)

5.08.1 The Company will ensure a suitable and sufficient risk analysis of all workstations* in use is undertaken. Appendix 5 of the Display Screen Equipment Regulations details a checklist.

5.08.2 The Company will ensure any identified risks are reduced to the lowest level reasonably practicable.

5.08.3 The Company Safety Consultant will review and revise the risk analysis if required when necessary.

5.08.4 All employees will be given a free eyesight test on request and at regular intervals thereafter.

5.08.5 Adequate training, information and instruction will be provided for all users of workstations.

* workstations include any alphanumeric or graphic display screen equipment (VDU's), microfiche screens and certain process control display screens.

5.09 ELECTRICITY AND ELECTRICAL EQUIPMENT

- 5.09.1 Any work utilising electricity or work on electrical equipment will be carried out in accordance with the requirements of the Electricity at Work Regulations 1989.
- 5.09.2 All electrical work will be carried out by trained, competent and authorised personnel.
- 5.09.3 The Company will ensure any electrical contractors / personnel engaged are competent to carry out the relevant work.
- 5.09.4 Fixed electrical installations on the company premises will be thoroughly inspected and tested by a competent person at the specified intervals.
- 5.09.5 Live working is prohibited on Company premises.
- 5.09.6 The Company will ensure all electrical equipment is properly isolated before covers, guards etc. are removed for maintenance purposes.
- 5.09.7 All fixed electrical equipment will be suitable, hard wired in and RCD protected where appropriate.
- 5.09.8 The Company will issue a permit to work for work on electrical plant and equipment.
- 5.09.9 Only trained, competent and authorised personnel are allowed to enter electrical panels and switchgear for the purposes of electrical maintenance, repair or the resetting of overloads.

5.010 ENERGY AND MACHINERY ISOLATION

5.010.1 The Company will ensure the risks associated with isolation of and working on energy systems, particularly where moving machinery is involved, are assessed.

5.010.2 Work will not proceed until: -

- Methods of isolation and discharge of stored energy are agreed and executed by a trained and competent person.
- Any stored energy is discharged (inc. vehicle hydraulics) by an agreed, safe procedure.
- A lock out procedure incorporating personal locks and warning notices is utilised at the appropriate isolation point.
- A test is conducted, e.g. start button pressed to ensure the isolation is effective.

5.010.3 The effectiveness of isolation procedures will be periodically monitored by the foreman.

5.010.4 Guarding and safety systems must be re established upon completion of work prior to using the plant and equipment.

5.010.5 Care must be exercised to ensure latent hydraulic pressure has been dissipated prior to work on any hydraulic system.

5.011 ENVIRONMENTAL PROCEDURES

A GENERAL

5.011.1 The Company will ensure arrangements are in place for: -

- Dealing with oil or fuel spillages
- Potential outfall pollution
- Storage and disposal of waste.

At Client sites all company employees and contractors will comply with the published waste disposal arrangements gained through site induction. All employees will be familiarised with any environmental emergency procedures. All employees will receive environmental awareness training where necessary.

5.011.2 The Company will ensure it is registered with the Environment Agency to produce hazardous waste.

5.011.3 The Company will periodically evaluate compliance with the applicable legal requirements and other requirements to which the Company subscribes. The Company will comply with the following guidance notes whenever practicable: -

- PPG01 General Guidance for the Prevention of Water Pollution
- PPG02 Above Ground Oil Storage Tanks
- PPG05 Works in or near or liable to affect Water Courses
- PPG08 Storage and Disposal of Used Oils
- PPG11 Preventing Pollution at Industrial Sites
- PPG13 High Pressure Water and Steam Cleaners
- PPG19 Garages and Vehicle Service Centres
- PPG22 Dealing with Spillages on Highways
- PPG26 Storage and Handling of Drums and Intermediate Bulk Containers.
- AQ17(3) DEFRA Guidance on Habitat Regulations
- CBI Code of Practice for Archaeology
- EMPG11 Mineral Planning Guidance
- BACMI Environmental Code
- PG318(04) Quarry Processes
- PG 3/16/04 Mobile Crushing and Screening

B. FUEL & OIL

5.011.4 Fuel and Oil will only be stored in secure (lockable), bunded containers which are double skinned. Supervision must be in attendance when fuels are being delivered or transferred to vehicles. All personnel should refrain from smoking in the vicinity.

5.011.5 Hoses and valves should be regularly checked for wear and where possible should be fitted with automatic cut out arrangements. Equipment should be

placed on drip trays to collect minor spillages and leaks. Trays and bunds should be checked regularly and any accumulated oil disposed of.

5.011.6 Where oils / fuels are stored in containers over 200 litres above ground the guidelines set out in PPG2 (Process Guidance Note) should be adhered to.

5.011.7 Spill kits and fire extinguishers will be available at all storage facilities.

5.011.8 Whenever practicable fuels and oils should be stored away from water courses, drains, ditches etc. and any risk from collision damage.

5.011.9 Care should be taken to wear the appropriate PPE when dealing with spills of fuel, oils, chemicals etc.

5.011.10 All spillages must be dealt with immediately and site management informed. Where spillages enter the water courses untreated the Environment Agency must be informed (emergency hotline 0800 807060).

C. NOISE AND VIBRATION

5.011.11 Noise and vibration will be minimised by utilisation of appropriate noise reduction equipment. Plant will not be left running unnecessarily.

D. WATER

5.011.12 Any surface water drains at the works will be maintained in good working order and a programme of regular inspection established where appropriate. Any oil interceptor system required to ensure polluted water does not leave the yard after spillage / cleaning operations will be regularly checked and emptied.

5.011.13 All oil based waste will be removed from site / premises by licensed, authorised carriers. The duty of care paperwork will be completed and retained for record purposes.

E. HAZARDOUS WASTE AND HOUSEKEEPING

* Hazardous waste is waste that due to its composition or the contaminants it has picked up during its use, e.g. waste oils, grease cartridges, oily rags, filters, batteries etc. has been identified as having hazardous properties with a detrimental effect on the environment.

5.011.14 Sites and workshops will be maintained in a clean, tidy and orderly state. Waste will be removed as it accumulates unless specific arrangements have been made with local management. 'Duty of Care' to properly manage will be complied with in relation to waste produced.

5.011.15 All employees will ensure that grease cartridges, gloves, rags, paint tins etc. and general waste, e.g. newspapers, lunch wrappings etc. are disposed of in the correct receptacle / skip etc. provided for the purpose as it accumulates.

5.011.16 The company will endeavour to minimise waste, recycling oils whenever practicable.

5.011.17 All waste will be disposed of by registered waste contractors, particularly oil based waste, e.g. oils, grease cartridges, oil rags etc. Waste consignment notes will be kept for a period of 3 years.

5.011.18 Waste will be stored in designated areas isolated from surface drains and bunded to contain spillages.

F. CHEMICALS / HAZARDOUS SUBSTANCES

5.011.19 Chemical substances hazardous to the environment, e.g. paints and solvents will be suitably handled and stored in accordance with the material safety data sheet for the substance. This will normally be lockable storage.

5.011.20 Surplus substances, packages, rags etc. will be removed from site by licensed carriers or disposed of in the appropriate receptacle.

5.011.21 Hazardous substances will not be left lying around where they may constitute a hazard to wildlife, children or unauthorised users.

5.012 ERECTION OF STRUCTURES

5.012.1 The Company will ensure that all site work is properly, planned supervised and executed in accordance with: -

- A site specific method statement for the erection work
- Control measures identified through the undertaking of site specific risk assessments

5.012.2 The published Company safe systems of work and work procedures will be adhered to at all times, particularly: -

- Unloading of materials
- Lifting operations
- Use of MEWP
- Weather
- Overhead power cables

5.012.3 Whenever reasonably practicable the Company will give consideration to the pre-assembly of steelwork at a lower level to reduce height working, e.g. lifting of rafters in pairs (joined at apex).

5.012.4 The Company will endeavour in developing the method statements to ensure ongoing stability through: -

- Erection of self-stable modules complete with necessary bracings
- Erecting columns commencing from a brace bay
- Non-erection of columns if they cannot be safely tied in at shift end
- Awareness of ad hoc windy weather conditions during the erection sequence

5.012.5 The Company will ensure that all routine lifting operations are planned, supervised and controlled by a demonstrably competent person, e.g. slinger / banksman.

5.012.6 Where lifting is of a complex nature a written lifting plan will be drafted and work supervised by an appointed person in addition to slinger / banksman.

5.012.7 Erection practice will so far as reasonably practicable conform with BS5531, HSE Guidance Notes and relevant BCSA Codes of Practice.

5.012.8 The site foreman will carry out a site appraisal and ensure ground conditions / foundations are suitable for safe operation of MEWP and erection of towers / scaffolds etc. and that safe stand off distances can be maintained from any overhead power lines.

5.012.9 The site foreman will ensure an exclusion zone is maintained around the works and entry by non-authorized personnel restricted.

5.012.10 The site foreman will ensure safe access, unloading and storage of all materials for use in the works, minimising double handling whenever possible.

5.012.11 The site foreman will ensure all plant and equipment particularly equipment used to gain height, e.g. scaffolds, MEWP, are effectively secured at shift end, weekends, holiday periods etc. against unauthorised use, trespassers, children etc.

5.013 FABRICATION

5.013.1 Whenever reasonably practicable the Company will ensure safety efficient design principles: -

- Minimise the number of members required for a given structure (less work and handling)
- Ordering stock steel to minimise amount of cutting to length (less work and handling)

5.013.2 The published Company safe systems of work and work procedures will be adhered to at all times, particularly: -

- Loading and Unloading
- Manual handling
- Lifting and Slings
- Welding
- Paint Spraying
- Use of Equipment

5.013.3 The Company will ensure safe positioning and storage of materials / components in and around the works to: -

- Prevent toppling of stacked materials due to instability or impact
- Limit the risks from slipping / tripping and falling

5.013.4 All personnel will be trained, authorised and competent to undertake their allotted tasks and in particular the materials handling operations.

5.013.5 All plant and equipment will be suitable for its purpose, regularly inspected and maintained.

5.013.6 The Company will ensure all necessary statutory inspections are undertaken and records kept as required, e.g. lifting equipment.

5.013.7 Monthly workplace inspections will be undertaken which will include all guarding, emergency stops and photo electric cut outs to machinery.

5.013.8 Contractors visiting the works to undertake servicing, maintenance and installation duties will be given a safety induction and will be required to provide: -

- Insurance documentation
- Certificates of competency
- Records of equipment inspection (where appropriate)

A permit to work will be issued.

5.013.9 Visitors to the workshops will be given an appropriate induction and accompanied throughout their visit where necessary.

5.013.10 All personnel, including contractors and visitors, will be required to wear the following PPE at all times: -

- Coveralls
- Ear defenders
- Steel toe cap safety boots
- Safety glasses
- High viz top (outdoors / No.2 bay)
- Gloves

Plus appropriate, task dependant PPE, e.g. respirators for paint spraying, grade 1 impact safety goggles in and around the shot blast area.

5.014 FIRE PRECAUTIONS

The Company will ensure a comprehensive risk assessment is undertaken for the company offices and works ensuring: -

5.014.1 Each building occupied by the company has notices displayed indicating: -

- Fire Exits and Escape Routes
- Fire Instructions

5.014.2 The emergency evacuation of the building is undertaken twice yearly.

5.014.3 Appropriate employees are trained so that they are aware of: -

- The procedures required to raise the alarm
- Action to be taken on discovering a fire
- Evacuation procedures
- Location and use of fire fighting equipment
- Location and use of escape routes

5.014.4 The provision and maintenance of sufficient quantities of appropriate fire extinguishers at the offices and works and a suitable means of detecting and raising the alarm in the event of fire.

5.014.5 The workplace is regularly inspected for potential fire hazards.

5.014.6 Safe hot working procedures are in place for all processes.

5.014.7 Prior to commencement of work on site the foreman of the site must liaise with the Principal Contractor and establish the Principal Contractor's requirements for dealing with fires and evacuation of the site.

5.015 FIRST AID

- 5.015.1 It is the responsibility of the foreman at the Client's site to ensure that the location of first aid equipment and first aid arrangements are known to all company employers working on site.
- 5.015.2 The Company will ensure a risk assessment of the company premises is carried out to ensure an adequate level of first aid capability is provided.
- 5.015.3 The Company will appoint suitable, trained persons to take charge of the first aid, accident and emergency arrangements.
- 5.015.4 The Company will ensure the required equipment is provided and that all employees are aware of the arrangements.

5.016 HAND TOOLS

- 5.016.1 The Company will ensure all hand tools provided are appropriate for the work, duty and environment in which they are used.
- 5.016.2 The Company will ensure all employees receive appropriate training in the use of hand tools.
- 5.016.3 The Company will ensure that a scheme of portable appliance testing is undertaken for all relevant equipment and a register kept by the Buying Department.
- 5.016.4 The Company will ensure specific risk assessments are undertaken for work equipment used by pregnant women or young persons.
- 5.016.5 The Company will provide suitable personal protective equipment to be worn when using power tools in accordance with the risk assessment.
- 5.016.6 Only electrical hand tools of 110v will be used on site. Hand lamps will be double insulated and checked for damage before use. Where 240v tools are used these will be RCD protected.
- 5.016.7 All power tools which become faulty or in need of repair must be returned to the foreman. Defective tools must NOT be used.
- 5.016.8 All equipment will be operated with correctly functioning guards and safety features.
- 5.016.9 Employees should pay particular attention to trailing cables to ensure they are not prone to damage and do not present tripping hazards.

5.017 HEIGHT WORKING

- 5.017.1 The Company will ensure that the risks associated with working at heights* or over / adjacent openings will be assessed. Height working will be minimised whenever possible. The Company will ensure work does not proceed unless appropriate measures are in place to prevent falls.
- 5.017.2 All work at height will be effectively planned, supervised and undertaken by personnel trained to work at height.
- 5.017.3 Effective precautions will be taken, in so far as is reasonably practicable to ensure that equipment, materials, etc., cannot fall onto persons below.
- 5.017.4 Climbing onto structures, plant and work equipment is to be avoided. Purpose made access platforms or mobile towers will be utilised as far as is reasonably practicable.
- 5.017.5 Generally ladders will be used as a means of access only and will be of sound construction, proprietary industrial standard (Class1), maintained and suitable for their intended purpose. Ladders will be used for work of low risk and short duration only.
- 5.017.6 Mobile elevating platforms (MEWP) will be used by trained, competent and authorised persons only and in accordance with manufacturer's instructions. A site specific risk assessment may need to be undertaken. Platform users will wear a suitably attached restraint harness and lanyard at all times here there is a risk of falling, e.g. potential instability or impact.
- 5.017.7 All Mobile elevating work platforms will be inspected by the user before being operated. The Company will ensure that a current report of thorough examination is available for the equipment.
- 5.017.8 Safety harnesses when used will comply with BS EN 361, i.e. full body harnesses, and shall include "shock absorbers" in the layout. Harnesses will be inspected prior to use and discarded if found defective, harnesses over 5 years old will not be used. Fall arrest systems should only be utilised when appropriate attachment points / running lines are provided and sufficient height exists so they can be used safely.
- 5.017.9 All work equipment for use at height should always be inspected before use and after impact / damage or if subjected to significant adverse weather conditions, i.e. windy.
- 5.017.10 Where personnel are required to access the back of trailers the proprietary steps / access only will be used and suitable fall protection systems erected / placed / installed around the trailer.

* A place is 'at height' if a person could be injured by falling from it, even if it is at or below ground level. This includes the means of access.

5.18 HOT WORKING

Hot work includes use of blow torches, oxy / fuel sets, electrical welding / cutting, certain angle grinder, reaming, drilling, profiling etc.

- .1 The Company will ensure only authorised personnel carry out hot work.
- .2 When working at site the Client may issue a permit to work for hot working. The site foreman will be responsible for obtaining and adhering to this.
- .3 The person carrying out the hot work will check his immediate work area for flammable materials, e.g. wood, oil, plastic pipes etc. and take the appropriate action i.e. removal, protection.
- .4 A suitable portable fire extinguisher will be required standing by.
- .5 All equipment used will be fitted with appropriate safety features, e.g. flash back arrestors. The equipment will be checked by the user for defects before use.
- .6 Appropriate PPE will be provided for use by the Company in accordance with the risk assessment, e.g. flameproof coveralls, respirator etc.
- .7 The work area should be monitored throughout and after the work for any signs of fire.
- .8 All employees carrying out hot work should be familiar with and follow the company's safe system of work for this activity.

.19 HOUSEKEEPING

Housekeeping issues fall into three categories: -

- i) Slips, trips and falls
- ii) Fire
- iii) Hygiene / vermin

- .19.1 The Company will operate a workplace inspection scheme to ensure all work areas remain free of slipping and tripping hazards, fire risks etc.
- .19.2 All employees are required to work in a clean and tidy manner disposing of oily rags, flammables, litter, grease cartridges, off cuts etc. in a timely and appropriate manner.
- .19.3 All employees should ensure tripping hazards are removed, spills are reported and cleaned up, trailing cables etc. are positioned sensibly so as not to create a risk.
- .19.4 Fire marshals will ensure through regular workplace inspection that fire exits and escape routes remain unblocked.
- .19.5 All employees should ensure that their workplace activities do not cause walkways, passages, exits etc. to become blocked.
- .19.6 Operators of Fork Lift trucks, cranes and side loaders should handle and stack all materials appropriately so as not to present a falling or tripping hazard.
- .19.7 Employees at both workshops and site should refrain from littering so as not to encourage rats, vermin etc. Significant sightings of rats should be reported to the line manager / site management immediately.

.20 LPG & OXYGEN

- .20.1 The Company will ensure all compressed gas cylinders are stored outside in a secure, well ventilated, weatherproof compound / cage.
- .20.2 The compound / cage will be divided to separate empty and full bottles. Suitable identification and warning notices will be displayed.
- .20.3 Oxygen cylinders will not be stored alongside LPG and a minimum number of cylinders will be kept on site.
- .20.4 Appropriate and sufficient fire extinguishers (dry powder) will be kept in the vicinity of the compound / cage.
- .20.5 The Company will operate a no smoking policy in the vicinity of the storage areas.

.21 LIFTING OPERATIONS AND EQUIPMENT

- .21.1 The Company will ensure all lifting operations are properly planned by a competent person (appointed) possessing adequate practical and theoretical knowledge and experience.
- .21.2 All lifting operations will be appropriately supervised in proportion to the risk.
- .21.3 For routine lifting operations the lifter / slinger will take charge, plan, supervise and carry out the lifting operation, i.e. using FLT, overhead crane.
- .21.4 The Company will ensure personnel not properly trained, authorised and appointed by the company will not carry out lifting operations.
- .21.5 Where the Company deems lifts to be of a complex nature a competent, appointed person will take charge and will carry out a written risk assessment and plan and brief all personnel involved in the operation.
- .21.6 All cranes used by the Company will carry a current certificate of thorough examination. Lifting accessories used must be marked with the Safe Working Load and be undamaged. All safety devices must be operational and tested.
- .21.7 It is the responsibility of the competent person to check the certificates of crane and accessories and inspect the lifting accessories before use. DAMAGED equipment will not be used.
- .21.8 The Foreman will ensure that the overhead cranes in the workshop are only operated by trained, competent and authorised personnel, likewise undertaking of the slinging operation.
- .21.9 All lifting equipment used with the overhead crane will carry a current certificate of thorough inspection.
- .21.10 The Company will ensure that all lifting equipment used at the works and on site is subject to a thorough examination in accordance with statutory legislation. A register will be maintained by the Buying Department. A colour tag system will be used to identify equipment inspected.
- .21.11 The Company will ensure that the overhead cranes at the workshops are maintained in accordance with the manufacturers' instructions.
- .21.12 The Workshop Foreman is responsible for ensuring the currency of certification and maintenance of all lifting equipment.
- .21.13 Care must be taken during lifting and maintenance operations at the workshops due to the live (conductor) nature of the crane tracks. All personnel involved will be made aware of the location of the conductors as appropriate.
- .21.14 The Company will ensure only trained, competent and authorised personnel operate fork lift trucks and side loaders.

- .21.15 All fork lift trucks will be inspected before use, regularly maintained and carry a current certificate of thorough examination.
- .21.16 Fork lift trucks will not be operated with any significant defects to brakes, steering, the lifting mechanism or reversing beepers.

.22 LONE WORKING

- .22.1 All lone working must be sanctioned by line management.
- .22.2 All employees should ensure that their whereabouts and activity is known to the appropriate site management.
- .22.3 The foreman should establish with the Client if a permit to work is required.
- .22.4 The employee in conjunction with the Client site management will ensure an emergency procedure and arrangements for regular contact are made and adhered to.
- .22.5 Adequate means of communication should exist. This may be by use of a mobile phone.
- .22.6 Only routine work will be undertaken. This excludes work near water, work at height or within a restricted space, any electrical work.
- .22.7 All personnel should be suitably trained, competent and familiar with the work being undertaken and medically fit and suitable to carry it out.

.23 MACHINE GUARDING

- .23.1 The Company will ensure that hazards presented by machinery and equipment will be suitably and sufficiently risk assessed to enable appropriate risk reduction measures to be implemented where required.
- .23.2 The Company will ensure that effective measures are taken to prevent access to any dangerous or moving part of machinery or to any rotating stock bar.
- .23.3 The measures implemented will normally consist of adequate strength, fit for purpose: -
- Fixed guards
 - Interlock guards
 - Protection devices, e.g. light curtain

Where this is not practicable other protection appliances will be used, e.g. jigs, holders, push sticks etc.

- .23.4 The Company will ensure guarding is regularly inspected and maintained and checked for correct operation weekly.
- .23.5 The Company will ensure all employees are provided with adequate information, instruction, training and supervision with regard to safe operation and use of the guarding arrangements.
- .23.6 The Company will ensure that guards and barriers fitted to mobile work equipment is suitably designed, effective, fitted and maintained to prevent contact with moving parts, e.g. scissor action, tracks, wheels etc.

.24 MANUAL HANDLING

- .24.1 The Contracts Manager / Workshop Foreman are responsible for the carrying out an assessment of any manual handling operations not covered by the generic assessments contained in the Company Safety, Health and Environmental Manual. A written version of all assessments is retained at head office. All appropriate personnel will be advised of the safe system of working arising from the assessment. A checklist is given in the attached Appendix to assist this procedure.
- .24.2 All assessments will be collated by the Company Safety Consultant.
- .24.3 The assessment will take account of: -
- The tasks
 - The loads
 - The working environment
 - Individual capability
 - Any other relevant factors
- .24.4 Appropriate steps will be taken by the foreman of the site to reduce the risk of injury to those employees carrying out manual handling operations to the lowest level practicable.
- .24.5 The Contracts Manager / Workshop Foreman shall ensure that manual handling activities are avoided where reasonably practicable.
- .24.6 The Company will ensure that employees are provided with the weight and centre of gravity of any load where appropriate.
- .24.7 All employees will receive training in manual handling activities where appropriate.

COMPANY SAFETY PROCEDURES – MANUAL HANDLING ASSESSMENT

APPENDIX

Factors to which the Contracts Manager / Workshop Manager must have regard and questions he must consider when making an assessment of manual handling operations.

Factors

Questions

1. The tasks

Do they involve:

- holding or manipulating loads at distance from trunk?
- unsatisfactory bodily movement or posture, especially:
 - twisting the trunk?
 - Stooping?
 - Reaching upwards?
- excessive movement of loads, especially:
 - excessive lifting or lowering distances?
 - Excessive carrying distances?
- excessive pushing or pulling of loads?
- risk of sudden movement of loads?
- frequent or prolonged physical effort?
- insufficient rest or recovery periods?
- a rate of work imposed by a process?

2. The loads

Are they:

- heavy?
- bulky or unwieldy?
- difficult to grasp?
- unstable, or with contents likely to shift?
- sharp, hot or otherwise potentially damaging?

3. The working environment Are there:

- space constraints preventing good posture?
- uneven, slippery or unstable floors?
- variations in level of floors or work surfaces?
- extremes of temperature or humidity?
- conditions causing ventilation problems or gusts of wind?
- poor lighting conditions?

4. Individual capability

Does the job:

- require unusual strength, height etc.?
- create a hazard to those who are pregnant or have a health problem?
- require special information or training for its safe performance?

5. Other factors

Is movement or posture hindered by personal protective equipment or by clothing?

5.25 MOBILE PLANT

- .1 The Company will ensure that all personnel required to operate mobile plant are sufficiently trained, competent and authorised.
- .2 All personnel will refrain from operating mobile plant for which they are not authorised.
- .3 The Company will ensure that all mobile plant is suitable for purpose, appropriately maintained and where required subject to a thorough examination by a competent person at the required interval.
- .4 The Company will appropriate a scheme of daily inspection for all its mobile plant.
- .5 Where mobile plant is hired in it will be supplied with all appropriate documentation and maintained and repaired by the hiring company.
- .6 Mobile plant will not be operated with significant defects, i.e. to steering, brakes, lifting mechanisms etc.

.26 NOISE

- .26.1 The Company will carry out a suitable and sufficient risk assessment of work activities which create noise by: -
- a. Observation of specific work practices
 - b. Reference to relevant equipment information
 - c. If necessary, measurement of noise levels.
- .26.2 Where necessary the Company will ensure noise levels are reduced to as low a level as is reasonably practicable by consideration of: -
- d. Less noisy working methods
 - e. Quieter work equipment
 - f. Consideration of the workplace layout
 - g. Training and information for employees
 - h. Technical considerations
 - i. Programmed equipment maintenance
 - j. Limiting the duration / intensity of exposure by consideration of work schedules, rest periods etc.
- .26.3 Where it is not practicable to reduce noise levels to below 85dB(A) suitable hearing protection will be made available and the area designated as an ear protection zone with appropriate warning signs displayed.
- .26.4 Employees are required to wear ear protectors when instructed to do so or where mandatory notices demand it or when noise levels reach 85dB(A).
- .26.5 The foreman of the site must ensure that employees subjected to noise at or above 85 dB(A) are **provided** with and **wear** suitable and efficient ear protection.
- .26.6 All employees will be instructed in the requirements and use of ear protection.
- .26.7 Where noise levels reach 80dB(A) hearing protection will be made available to all employees who request it.

.27 OVERHEAD / UNDERGROUND SERVICES

- .27.1 The foreman of a site must ensure through the Principal Contractor that every accessible part of a service trench, excavation or opening in the ground into which personnel are liable to injury from falling or driving / operating mobile equipment into is securely fenced or covered as near to possible to the edge of that trench etc.
- .27.2 The foreman of a site, through the Principal Contractor, shall ensure the presence of underground services are detected and marked, prior to erection or use of craneage, mobile elevating work platforms etc.
- .27.3 The Company will ensure no work is carried out in the vicinity of live overhead power lines, i.e. within 9 metres if supported by wooden poles, 15m if carried on pylons, without prior consultation with Client site management and an adequate risk assessment being provided.
- .27.4 The Company will ensure where plant is required to traverse (but not work) immediately adjacent to overhead power cables the plant will not pass within 6 metres of the power line.
- .27.5 Power lines should be marked with goal post type warnings in accordance with Fig. 2 of GS6 – Avoidance of Danger from Overhead Electric Lines.

.28 PAINTING AND SPRAYING

- .28.1 The Company will ensure that all paints, solvents and materials used are suitable for their intended purpose and represent the minimum risk to persons using or exposed to them.
- .28.2 The Company Foreman will maintain a register of substances and assessments readily available to all for consultation as to their safe method of handling and use.
- .28.3 All personnel using substances must familiarise themselves with relevant information concerning paint / solvent use etc.
- .28.4 All personnel engaged on painting and spraying tasks will be trained, competent and authorised to undertake such work.
- .28.5 All personnel engaged on painting and spraying tasks are required to wear, maintain and suitably store the required appropriate respiratory protection.
- .28.6 The Company Foreman will ensure that all materials, paints and solvents used are correctly stored at all times in suitably signed, ventilated and lockable containers.
- .28.7 All personnel involved in paint spraying will work in a tidy and economical manner minimising over spraying whenever possible and ensuring the spray area is regularly cleared of build up / spent paints etc.
- .28.8 The Company will provide, maintain, inspect and test suitable fume extraction equipment for the purposes of spraying activities.
- .28.9 All personnel involved in spraying activities will ensure that the extraction systems operated are utilised at all times when spraying along with the activation of any warning signs, beacons etc., keeping all unauthorised personnel out of the area.
- .28.10 All personnel will be familiar with the emergency procedures and the maintenance of fire fighting measures within the vicinity of paint spraying operations.

.29 PERMIT TO WORK

- .29.1 Certain activities will not be undertaken unless a 'Permit to Work' has been issued by Client site management. Typical activities include:-
- Electrical work (greater than or equal to 415v)
 - Entry into confined spaces
 - Certain work at height
 - Complex lifting (cranes)
- .29.2 All employees named on the permit should familiarise themselves with the permit conditions and control measures specified. Only employees named on the permit may undertake the specific work.
- .29.3 The permit signatory (site foreman) must ensure that all personnel abide by the conditions specified on the permit.
- .29.4 The foreman should keep the permit available until the specified work is complete and subsequently present it for cancellation. Only the person who accepts the permit may clear it and present it for cancellation.
- .29.5 All equipment must be safe, guards reinstalled etc. before the permit to work is cleared. This is the responsibility of the permit signatory.
- .29.6 Sub contractors working at the Company premises / works may require a permit to work for certain activities, for example: -
- Electrical work
 - Work at height

This will be issued by the Workshop Foreman.

.30 PERSONAL PROTECTIVE EQUIPMENT

- .30.1 The Company will provide personal protective equipment (PPE) where risks to health and safety arising from the work cannot be controlled by other means as determined by risk assessment.
- .30.2 All employees will be trained in its use, protection, compatibility and limitations.
- .30.3 All personnel are required to wear PPE as designated, e.g. on display of mandatory warning signs, or as required through risk assessment. Employees must report any losses or defects.
- .30.4 Mandatory PPE to be worn in the workshops includes: -
- Steel toe cap safety boots
 - Safety glasses
 - Ear protection
 - High visibility top (bay 2 and yard area)
- .30.5 The site and workshop foreman are required to enforce the wearing of PPE.
- .30.6 Construction sites require mandatory wearing of PPE including:-
- Safety helmet
 - High visibility overalls and waistcoats
 - Steel toe cap safety boots
 - Safety glasses
 - Gloves
- Dust masks and ear protection are required in certain circumstances.
- .30.7 PPE must not be abused, used only for its intended purpose and where appropriate inspected for defects prior to use.
- .30.8 The Company will ensure proper facilities exist for the safe storage of PPE.
- .30.9 The Company will provide and ensure suitable eye protection is worn where there may be a risk of eye injury, e.g. using angle grinders or shot blasting activities.
- .30.10 Suitable respiratory protection is required for welding and paint spraying activities.
- .30.11 Where safety harnesses and lanyards are required to be worn employees will be fully trained and competent in their use.
- .30.12 The Contracts Managers / Workshop Foreman will maintain a record of all PPE issued.

.31 PLANT AND EQUIPMENT

- .31.1 The Company will ensure that all equipment provided for use at work is maintained in an efficient state, in efficient working order and in good repair.
- .31.2 The foreman of a site will ensure that work equipment supplied to company employees for use at work is suitable for its intended purpose.
- .31.3 The Company will ensure that employees have been provided with adequate information and training to use the work equipment provided in a safe manner.
- .31.4 Where practicable employees should inspect their work equipment prior to use, report and take out of service any work equipment which is considered or found to be defective. Such equipment should be labelled accordingly and reported to the foreman.
- .31.5 The Company will keep maintenance records of all appropriate equipment.
- .31.6 The Company will ensure work equipment carries a current certificate of thorough inspection where appropriate, e.g. lifting equipment.
- .31.7 Employees must use work equipment in accordance with their training and the manufacturer's instructions.
- .31.8 Where work equipment is hired in the Company will ensure it is fit for purpose, safe to use and carries any relevant statutory certification.

.32 PRESSURE SYSTEMS

- .32.1 All pressure systems will be designed, constructed, installed and operated in accordance with Statutory Regulations.
- .32.2 The Company will ensure a written scheme of examination is drafted and complied with.
- .32.3 All system operators will be trained and competent to use pressure equipment.
- .32.4 The Company will ensure equipment is not operated with defective safety devices.
- .32.5 The Company will ensure a regular maintenance and inspection scheme is undertaken in accordance with the manufacturers / installers instructions.

.33 RISK ASSESSMENT

- .33.1 The Contracts Manager / Workshop Foreman are required to carry out a suitable and sufficient assessment of the risks to health and safety of company employees before work commences in order to identify the action necessary to comply with the requirements of any relevant statutory provision.
- .33.2 The assessment will normally cover: -
- Identification of any **significant** risk that is reasonably foreseeable
 - Action which needs to be taken, and what the priorities should be
- .33.3 The risk assessment must be in writing and retained at the Company headquarters.
- .33.4 Risk assessments will be undertaken for all work. The Company Safety Consultant will assist where required. Generic risk assessments are contained within the Company Safety, Health and Environmental Manual.
- .33.5 Employees shall be made aware of the risks identified and of the control measures required to alleviate the risks.
- .33.6 All risk assessments will be reviewed annually or when circumstances change, accident investigation dictates or legislation changes whichever is the sooner. The Company Safety Consultant will undertake the review.

.34 SAFETY SIGNS AND WARNING NOTICES

- .34.1 All safety signs erected by the company will comply with the Statutory Regulations.
- .34.2 The Contracts Manager for a site will assess areas where safety signs are to be displayed and ensure that they are displayed.
- .34.3 All employees, self employed persons and contractors working for the company must abide by company safety signs and signs erected by third parties on site or at the works.
- .34.4 The Company will ensure that mandatory hearing protection signs are in position where noise level measurement requires it.

.35 SCAFFOLDING AND MOBILE TOWERS

- .35.1 The Company will ensure only trained, competent personnel will direct the erection, erect, modify, dismantle and inspect scaffolds and mobile towers.
- .35.2 Employees are not authorised to erect / modify / inspect **fixed** scaffolds. This will be done by the erection company.
- .35.3 Mobile tower scaffolds will be erected / modified / inspected in accordance with the manufacturer's instructions by authorised, competent employees of the company.
- .35.4 All scaffolds / towers will be visually checked by the user before use.
- .35.5 **Fixed** scaffolds will be inspected weekly and a record made. This will be carried out by the erection company.
- .35.6 The site foreman will ensure the weekly statutory inspections of scaffolds are made and records kept.
- .35.7 The site foreman will ensure **fixed** scaffolds are re-inspected / repaired / modified by the erection company if adverse conditions at site are encountered, e.g. impact or adverse weather, i.e. wind.

.36 SITE PROCEDURES

- .36.1 The Contracts Manager will ensure a project specific method statement is prepared for all site contracts. The statement will include: -
- Job Name / Title / Client
 - Description of Works
 - The Company contact names / phone numbers
 - Name / details of erection company (if not HS)
 - All relevant risk assessments (including COSHH assessments)
 - Method of lifting / lifting plan (including crane details)
 - Method of height working (including MEWP, scaffolds etc.)
 - Designer approved method of erection
 - Any specific access arrangements / ground preparation arrangements
 - All relevant competencies, licences etc. of personnel involved
 - Copies of all statutory inspections for the lifting equipment to be used.
 - Emergency procedures
- .36.2 The Contracts Manager will ensure all site personnel including subcontractors and agency workers are familiarised with the necessary method of erection, safety precautions and emergency procedures.
- .36.3 Where the use of powered access equipment is not practicable specific risk assessments will be undertaken and a safe method of working agreed with the Client / Principal Contractor by the Contracts Manager.
- .36.4 Regular site inspections will be undertaken by the Contracts Manager to ensure method compliance.
- .36.5 The Contracts Manager will ensure all subcontractor personnel have valid certificates and equipment licences and that relevant plant / equipment at site have the required statutory examination certificates (current).
- .36.6 The Contracts Manager will ensure the relevant sections of the CDM Regulations are complied with, including: -
- .36.7 Liaison with all other contractors in relation to exchange of safety information.
- .36.8 Provision of any information required for inclusion in the Health and Safety File.
- .36.9 All personnel including visitors are required to undertake a site safety induction by the Client / Principal Contractor. All visitors will be accompanied.
- .36.10 All personnel, including visitors, are required to wear PPE at all times, this will normally be: -
- Safety helmet
 - Steel toe cap, ankle supporting safety boots
 - Clean high viz top
 - Abrasion resistant gloves
 - Suitable safety glasses (low impact)

Plus appropriate task dependant PPE, e.g. welding masks / goggles when welding.

- .36.11 The Company will ensure that the completed structure is handed over to the Client / Principal Contractor in accordance with the agreed specification and in a safe condition, e.g. grouted.
- .36.12 The Company will ensure the site is left in a clean, tidy and safe condition.
- .36.13 Any waste arising will be disposed of under the appropriate duty of care paperwork.
- .36.14 The Contracts Manager will ensure, in so far as is practicable, that all deliveries undertaken by the Company or through haulage contractors are made through the site security / reception / visitor procedures. Whenever possible haulage contractors will be advised of the basic site rules for delivery prior to attendance at site.

.37 STORAGE AND STACKING

- .37.1 Company Foreman will ensure that materials are stored in a safe and tidy manner so as not to put personnel at risk from toppling due to instability or inadvertent impact.
- .37.2 Personnel will not stack or bundle materials in a manner such that smaller components cannot be seen or are at risk of falling during handling operations.
- .37.3 Cylindrical articles will be secured to prevent inadvertent movement.
- .37.4 Company Foremen will ensure that all stacked articles are safely spaced utilising hardwood (undamaged) timber packs at all times.
- .37.5 Personnel operating lifting and stacking machinery such as side loaders and fork lift trucks must be trained, competent and authorised to use such plant.
- .37.6 Company Foreman will ensure that fire exits, walkways, thoroughfares etc. are kept unblocked by the inappropriate storage / stacking up of materials. Particular attention must be given to maintaining freedom of movement of personnel particularly in the event of emergencies.
- .37.7 Where stands / stillages are utilised they will be of sufficient number, robustness, size and orientation to ensure articles and components can be safely positioned, stored for fabrication, turning, spraying, preparing etc.

.38 SUBCONTRACTORS AND AGENCY WORKERS

- .38.1 The Company will ensure that all subcontractors and agency workers comply with the relevant procedures detailed in the Company Safety, Health and Environmental Policy and Procedures Manual.
- .38.2 The Contract Managers will ensure that all personnel are competent to undertake their allocated duties.
- .38.3 The Contract Managers will check and ensure that subcontract personnel and agency workers hold: -
- A valid current licence for any vehicle or equipment to be operated.
 - Proof of competency from the employer / agency
 - Evidence of safety training
 - A valid certificate of insurance
- .38.4 The Company will ensure that all Company personnel are issued with appropriate personal protective equipment to undertake their allocated duties. The Contract Managers will ensure all subcontract and agency workers carry and wear appropriate personal protective equipment.
- .38.5 The site foreman will ensure that all subcontractors undertake both a Client safety induction and an appropriate Company induction prior to commencement of work.
- .38.6 The Contract Managers will ensure that subcontractors provide method statements and risk assessments for the work being undertaken or are familiarised with Company documentation and that all personnel are familiar with the safe methods required.
- .38.7 The Contract Managers will ensure all subcontract personnel are familiarised with any specific hazards and risks present on the site, e.g. overhead obstructions, power cables etc.
- .38.8 The Contract Managers will ensure all plant and equipment brought onto site by subcontractors is properly maintained, safe to use, fitted with any necessary guards and safety devices and is accompanied by any necessary certificates of thorough inspection, e.g. lifting equipment.

.39 VIBRATION

.39.1 The Company will assess the risk of exposure of its employees to vibration above the daily exposure action value (EAV): -

- Whole body vibration: 0.5m/s² A(8)
- Hand / arm vibration: 2.5m/s² A(8)

.39.2 The Company will ensure that employees exposure to vibration is reduced to as low a level as is reasonably practicable by: -

- Consideration of revised working methods
- Provision of appropriate work equipment requiring the minimum amount of force
- Regular maintenance of work equipment
- Providing suitable and sufficient information and training
- Limiting exposure through adequate rest periods and provision of appropriate PPE and reduction of equipment use.

.39.3 The Company will ensure that employees are placed under suitable health surveillance if appropriate.

.39.4 The effects of hand-arm vibration to which power tool operators, e.g. angle grinders, are exposed to will be minimised by: -

- Appropriate selection of suitable plant and equipment
- Ensuring operation of plant and equipment in accordance with manufacturer's instructions
- Limiting the use of high vibration tools
- Regular maintenance of plant and equipment particularly: -
 - By not using blunt tools
 - By regular replacement of consumable items such as grinding discs

.40 VISITORS

- .40.1 All visitors to a Client site must be directed to the Principal Contractor's site office to sign in and obtain an appropriate induction.
- .40.2 The Company foreman at the site has a duty to ensure the health and safety of visitors connected with the company operations on site and will supply the visitor with what personal protective equipment has been assessed as necessary and ensure visitors are suitably accompanied throughout the visit.
- .40.3 Visitors are not allowed to use their own vehicles at site.
- .40.4 All visitors to the Company offices will sign the visitor's book and be given an appropriate induction in regard to emergency procedures etc.
- .40.5 Where visitors to the Company offices are visiting the works a detailed site induction will be given. Visitors will be required to wear appropriate personal protective equipment and be accompanied throughout the visit.

.41 WEATHER

.41.1 The foreman at site will regularly monitor weather conditions and take appropriate decisions.

.41.2 Weather conditions which could have an adverse effect in erection work include: -

- Rain or dew leaving steel wet
- High winds which may cause light components to blow about or loads to swing or part-erected structures to become unstable
- Frost, ice or snow creating slippery surfaces
- Fog, mist or glare impairing visibility

The site foreman will refer to the Contracts Manager if clarification is required.

.41.3 Where work is stopped measures will be taken where necessary to maintain the stability of the remaining part erected structure.

.41.4 Where wind strength increases rapidly it may be necessary to: -

- Guy columns / dismantle columns
- Create a strictly controlled exclusion zone

The site foreman will refer to the Contracts Manager if clarification is required.

.41.5 The stability of any previously erected component left in a potentially unstable state will be re-assessed by the site foreman prior to re-commencement of erection activities and the methodology modified where appropriate.

.41.6 Where site workers are potentially exposed to ultraviolet (UV) rays in sunlight for long periods the site foreman will ensure all personnel remain protected. Measures to be considered will include: -

- Being careful in summer in the three or four hours around midday
- Taking breaks in the shade where practicable
- Keeping the back of necks and heads covered
- Keeping the upper torso covered at all times
- Application of sun screens with an SPF rating of 15 or more

.41.7 It will be the responsibility of all employees to take care of their skin being particularly vigilant for reddening of skin, spotting of newly formed moles or skin discolouration. A doctor should be consulted if there are any concerns.

.42 WELFARE FACILITIES

- .42.1 The Company will supply suitable and sufficient washing and sanitary conveniences at all its work locations.
- .42.2 The Company will ensure adequate and readily accessible supply of drinking water marked with an appropriate sign.
- .42.3 Suitable and sufficient accommodation including facilities for drying clothing where appropriate will be provided.
- .42.4 Sufficient and suitable facilities for men and women for the changing of clothing will be provided where required.
- .42.5 Rest rooms will be provided at readily accessible places with facilities which will include: -
- Facilities for pregnant women to rest
 - Arrangements for preparing and eating meals
 - Means of boiling water
- .42.6 The Company will position no smoking signs to all facilities and ensure that this legal requirement is adhered to.
- .42.7 The Company will seek permission to use facilities provided by the Principal Contractor at Client's sites for site based contracts personnel.

.43 WORKPLACE ACCESS AND EGRESS

- .43.1 The Company will ensure that a safe means of access and egress is maintained to, from and within its premises. Each workplace will be suitably organised to ensure pedestrians, vehicles and plant can circulate in a safe manner.
- .43.2 All access facilities, e.g. roads, walkways, thoroughfares etc. will be maintained in good repair and free from excessive potholes, tripping hazards and the like.
- .43.3 The Company will ensure that: -
- i) Precautions to prevent personnel or materials falling from open edges / through holes or voids are in place.
 - ii) Floors, corridors and walkways are kept free of obstructions.
 - iii) Outdoor routes are kept safe during icy / wet conditions, e.g. by gritting or salting.
 - iv) Glazing is safe, toughened, protected and marked where necessary to make it easy to see.
 - v) Windows can be opened and cleaned safely without personnel falling through.
- .43.4 All personnel are required to keep to recognised / defined walkways at all times.

.44 YOUNG PERSONS

.44.1 Young Persons (under 18 years old) will be supervised at all times.

.44.2 Young persons will not be employed unless an assessment of risks to their health and safety has been carried out.

.44.3 In making the assessment of the risks particular account will be taken of: -

- The inexperience, lack of awareness of risks and immaturity of young persons.
- The nature, degree and duration of exposure to physical, biological and chemical agents.
- The form, range and use of work equipment and the way it is handled.
- The extent of the health and safety training provided or to be provided.

6 SAFE SYSTEMS OF WORK

6.1 INDEX

No.	Description	Date
SSW01	Manual Handling	01/01/11
SSW02	Isolation Procedure	01/01/11
SSW03	Hot Work	01/01/11
SSW04	Electrical Power, Tools and Equipment	01/01/11
SSW05	Lifting Operations	01/01/11
SSW06	Electric Arc and Inert Gas Shield Welding	01/01/11
SSW07	Flame Cutting and Welding	01/01/11
SSW08	Use of Pedestal Grinders	01/01/11
SSW09	Working at Height	01/01/11
SSW10	Use of MEWP	01/01/11
SSW11	Welding of Lifting Eyes	01/01/11
SSW12	Use of Ladders	01/01/11
SSW13	Use of Fork Lift Trucks (FLT)	01/01/11
SSW14	Use of Mechanical Band Saw	01/01/11
SSW15	Use of Solvents / Spraying	01/01/11
SSW16	Operation of Mobile Plant	01/01/11
SSW17	Unloading / Loading of Steel Stock / Components with FLT	01/01/11
SSW18	Lone Working	01/01/11
SSW19	Use of Hand Held Vibrating Tools	01/01/11
SSW20	Use of Overhead Crane	01/01/11
SSW21	Use of Combination Metalworking Machines	01/01/11
SSW22	Use of Scaffolding / Mobile Towers	01/01/11
SSW23	Manoeuvring Steel Stock / Components into Workshop using Fork Lift Truck	01/01/11
SSW24	Use of Guillotine	01/01/11
SSW25	Operation of Peddinghaus FPB1500 (Plasma Cutter)	01/01/11
SSW26	Operation of Shot Blasting Equipment	01/01/11
SSW27	Operation of Kaltenbach Circular Sawing Machine	01/01/11
SSW28	Operation of Peddimat TDK 1000/3C Drilling Machine	01/01/11
SSW29	Operation of FDB2 (Oxy/acetylene cutter and hole driller)	01/01/11
SSW30	Hand Held Disc Grinding and Cutting	01/01/11
SSW31	Use of PPE	01/01/11
SSW33	Use of Magnetic Drills	01/01/11
SSW34	Use of Radial Drill	01/01/11

SSW35	Unloading / Loading Steel Stock with Overhead Crane	01/01/11
SSW36	Use of Trestles and Stands	01/01/11
SSW37	Entry into Electrical Panels (Resetting Overloads)	01/01/11
SSW38	Use of Hazardous Substances	01/01/11

SAFE SYSTEMS OF WORK**Manual Handling**

1. Manual handling should be kept to a minimum, where practicable mechanical lifting aids should be used.
2. Where possible get assistance. Remember guidance for a 2 person lift is 30kg whilst 3 is 37kg (all at waist height).
3. Wear suitable personal protective equipment, i.e. close fitting, good grip gloves, steel toe cap safety boots with a non-slip sole and toe protection, coveralls and a high viz top.
4. A manual handling risk assessment must be carried out where heavy or awkward components are to be manually lifted. This will need to consider: -
 - a) The load to be lifted/supported, taking into account the weight, shape, size, centre of gravity, stability of, position, sharp edges, load type etc. Restrict load to 25kg whenever possible.
 - b) The environment surrounding the manual handling operation, looking for trip hazards, slippery surfaces, other traffic, lighting, fixed and mobile obstacles. **PLAN YOUR ROUTE**
5. Check the weight to be lifted. Lift a corner or rock it to establish if it is too heavy for you to lift.
6. Use the correct lifting technique, keeping a straight back (but not necessarily vertical, bending at the knees, using the thigh muscles for lifting NOT back muscles) and avoiding stretching, bending, twisting, straining and trapping bodily parts. Spread your weight evenly. Keep the load held close to your body whenever possible.
7. If you have a previous back injury consider using a support belt.
8. Do not lift items which have a dimension greater than 750mm on your own.
9. Do not carry for distances greater than 10m without taking a break (set the load down).
10. Do not push / pull loads further than 20m without a break.
11. Watch out for traffic / moving vehicles and adhere to the designated walkways.
12. Remember it is better to push than pull. Don't use jerky movements to start the load moving.

IF IN DOUBT ASK

Date: 01/01/11

SAFE SYSTEM OF WORK**Isolation Procedure (Machinery)**

When carrying out any maintenance, repairs or removing guards this procedure must be adhered to.

1. Ensure the O&M Manual for the machine is consulted to ensure the required safe procedure is adopted.
2. The machine and any associated equipment items must be “locked out” at the isolator using an ISO lock and lock guard (multi lock).
3. Ensure that the correct items of machinery are isolated. **Attempt to start the plant to confirm non operation.**
4. Each person working on a machine must place their lock on the isolator. Warning notices should be posted.
5. Retain the lock key on their person to prevent unauthorized start up of machinery.
6. Do not unlock the isolator until the guards are re-secured, machine safe to run and the areas clear.
7. There must be only ONE key for each lock being used.

Prior to any work being undertaken any stored energy should be dissipated from the system. This is particularly important with hydraulic systems.

This procedure shall operate in conjunction with any specific site isolation procedure and permit to work procedures operated by the Client.

IF IN DOUBT ASK

Date: 01/01/11

SSW03**SAFE SYSTEM OF WORK****Hot Work**

When carrying out “hot work” this procedure must be adhered to. Hot working includes flame cutting, welding, grinding, drilling, power cutting, mechanical sawing and electrical testing.

1. A permit to work / authorisation may be required prior to work commencement when carrying out work on site.
2. A full assessment of the surrounding area (including above and below) must be carried out for flammable material or any other materials that may be a fire hazard or may be damaged by heat or flame. Be aware of fuel lines and tanks, conveyor belts, pressurised tyres, aerosol spraying operations etc.
3. If flammable hazards are found in the area if possible they or the work should be moved to a safe area.
4. If the work cannot be moved to a safe area and the area cannot be cleared of fire hazards i.e. wooden floors, rubber components etc. a suitable fire proof cover must be used. Remember to cover any openings through which hot particles / sparks may pass.
5. Remain vigilant for signs of fire whilst hot work is carried out and ensure a suitable fire extinguisher standing by. Check around the area after completion for any signs of potential for a fire starting.
6. Ensure there is a means of escape in an emergency and the procedure for raising the alarm and calling the fire services is known.
7. Suitable personnel protective equipment must be worn including medium impact safety goggles, steel toe cap safety boots, safety helmet, gloves (usually gauntlets) and fireproof coveralls.
8. Where possible always ensure the work piece is effectively secured and NOT hand held.
9. Arrangements should be made to ensure unauthorised personnel cannot inadvertently handle hot components, hot slag, off cuts etc.

This procedure should be followed in conjunction with any other safe systems of work relevant to the task being undertaken.

IF IN DOUBT ASK

Date: 01/01/11

SAFE SYSTEM OF WORK**Electrical Power, Tools and Equipment**

When using hand held power tools, equipment, extension leads etc. this procedure must be adhered to:-

1. Before connection of any power tool or extension lead a thorough visual examination should take place before use, taking into account general condition, casing / insulation damage, loose plugs, damaged cable, attachment of a current P.A.T. label (3 monthly test).
2. Where transformers are used these should be of the centre tapped earth type to limit shock risk.
3. Guards should be correctly set, in position and NOT removed during use. Equipment which would normally have a guard should NEVER be operated without it.
4. Maintenance, changing bits, discs etc. should NOT be carried out unless the equipment has been properly isolated (switching off is NOT sufficient).
5. Ensure appropriate PPE is worn when using all tools and equipment including approved eye and hearing protection. Use a suitable face, dust mask if operation creates dust. Do not wear loose fitting clothing and tie back long hair.
6. Inspection your equipment before use. Defective equipment must not be used. Quarantine if pending repair. Ensure all tools are suitable for their task.
7. The standard power supply shall be 110 volts. Equipment above 110 volts must not be used where reasonably practicable and NOT in damp, wet conditions. If 240v or 400V equipment is required these should be RCD protected, checked for defects prior to use.
8. Care must be taken so that cables and extensions are not a trip hazard and that they are in an area where damage to them is unlikely to occur.
9. Personnel using hand power tools should be trained, instructed and competent in their use. Hand power tools should never be left operating and unattended. SWITCH IT OFF.
10. Personnel using any hire equipment should be made familiar with its operation and functions by means of a demonstration from the hire company, or use of the manufactures instructions and recommendations before it is put into use.
11. An assessment must be made of the work environment, i.e. if drilling, the whereabouts of cables, pipes and other services, and whether atmosphere explosive, before use.

SSW04

12. Ensure the work piece is suitably fixed, preferably by clamps before offering the equipment to it, as and when applicable.

IF IN DOUBT ASK

Date: 01/01/11

SAFE SYSTEM OF WORK**SSW05****Lifting Operations**

All lifting operations must be planned and supervised by suitably experienced, competent personnel. Ensure you check local site rules for lifting operations.

1. For **routine lifting** operations the appointed person for the lifting operation must be a qualified lifter/slinger or FLT driver who will be required to follow the lifting plan outlined in this procedure. Ensure you are holding a current qualification.
2. For a **complex lifting** operation the appointed person must be fully trained with adequate practical, theoretical knowledge and experience who will be required to complete the written risk assessment and lifting plan outlined in this procedure. Ensure you hold this additional qualification (appointed person).
3. Check the crane is operated by a demonstrably trained authorised and competent person (licensed) who has been suitably inducted.
4. Check the crane carries a current certificate of thorough examination and test as should any lifting equipment to be used i.e. chains etc. The cranes weekly report record should be completed and up to date. **Ensure the crane is large enough to pick up the weight safely.**
5. Do not operate a crane with known defects. Ensure all warning / alarm systems are correctly functioning before lifting.
6. Check all lifting equipment for defects* before use and ensure it is marked with its safe working load. Any defective lifting gear must be immediately taken out of use and must not be re-used until repaired and re-tested and a valid certificate issued. **Ensure the chains are correctly rated for the weight to be lifted.**
7. Inform the crane driver who will direct him (the slinger or appointed person) except for the emergency stop signal which may be given by anybody. Ensure the slinger is wearing distinctive high viz so that he can be readily identified.
8. Ensure the crane is positioned on stable ground, avoiding manholes, services, trenches etc and utilises fully extended outriggers supported on railway sleepers or steel plates.
9. Cordon off the lifting area whenever possible and restrict access to persons involved in the lifting operation only. Safe positioning of all personnel should be maintained throughout the lifting operation.
10. Where appropriate ensure the load is prevented from swinging by the use of guy ropes, however lifting operations should **never** be carried out in high winds.
11. Ensure the crane is NOT operated **within 600mm** of a fixed structure and **never** within **jib length plus 9** metres of overhead power cables (15 metres for HV). Always ensure there is sufficient visibility in which to undertake the lifting operation safely.

SSW05

12. DO NOT lift over people or occupied buildings.
13. DO NOT shorten slings/chains, unless you have been trained to do so.
14. **Ensure you know (reasonably accurately) the weight to be lifted.** The warning systems of the crane are not to be relied upon. An assessment of the weight should be gained from a competent person if there are no other means available to gain a realistic weight.
15. Comply with the following lifting plan for **routine** operations
 - a) Assess the load weight
 - b) Choose the correct sling / chain
 - c) Check the swept path for obstructions
 - d) Assess the ground for stability
 - e) Check for proximity of overhead power lines / obstacles
 - f) Prepare a suitable place to set down
 - g) Sling the load appropriately
 - h) Make a trial lift if necessary (to determine load stability)
 - i) Lift / sling the load ensuring no personnel or traffic are in the vicinity.
 - j) Set down and release the slings.
 - k) Tidy up.
16. Complete the attached **written** risk assessment / lifting plan for all lifting operations.

* Lifting equipment means work equipment for lifting or lowering loads and includes the attachments used for anchoring, fixing or supporting.

IF IN DOUBT ASK

Date: 01/01/11

SAFE SYSTEM OF WORK

Use of Mobile Crane for Lifting Operations
Lifting Plan/Risk Assessment

Lift to be carried out.....

Date of lift –

1 The Load and the Lift Team

2 The Location

3 The

4 The Lifting Equipment

Weight of load person

Crane access –

Height OK

Yes / No

Appointed

(certificated slings)

Width of load

Width OK

Yes / No

Swept path OK

Yes / No *

Weight restrictions

Yes / No

Crane

driver

Height of lift

(State max weight)

Other

persons

Radius of lift

Rigging area OK

Yes / No / NA

involved

Loose materials contained

Yes / No / NA

Work area level

Yes / No

Are lifting points adequate

Yes / No / NA

Ground bearing OK

Yes / No

Special lifting beams needed

Yes / No

Any obstructions (identify

Yes / No *

obstruction)

Structural stability OK

Yes / No * Lifting over a public road

Yes / No *

CPCS / CPA

Cards

No./Exp

Persons being lifted

Yes / No * Can crane driver see

Crane Driver

Full load path

Yes / No *

Appointed

Person

Overhead power cables

<9m Yes / No *

Building / Structures

<600mm Yes / No *

5 The Crane

6 The Certification

7 The Weather

Make, model, size

Check operation of SWL indicator

Yes / No

Thorough examination (6 Month)

Date of examination -

Description of weather conditions: -

Outrigger location

Jib erection/dismantling required

Yes / No

Test & examination (4 yearly)

Date of examination -

Special ballast required

Yes / No

Two cranes needed

Yes / No *

Weekly F91 Inspection

NOTE: Include the weight of the crane plus load weight when assessing ground stability if g.

Are conditions suitable to continue with i.e. **no** significant wind

Mobile Crane – Lifting Plan / Risk Assessment (contd.)

Sketch

Additional information/notes

(identified obstructions, etc.)

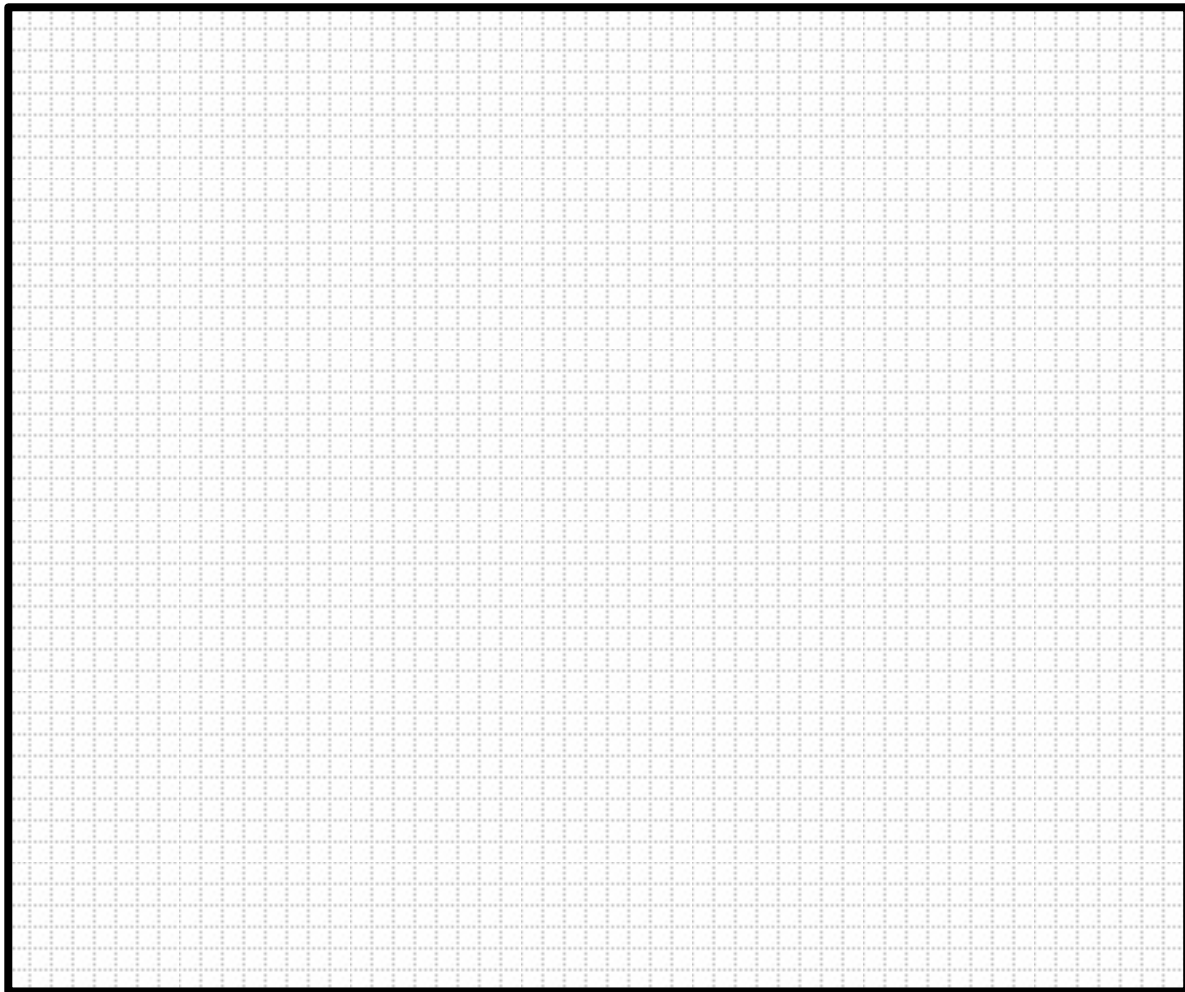

The lift must
assessment
responses u
taken.

Risk assessm

SSW5 to be follow
with * receives an
will be required and
charge and superv

Assessment carri

by.....

SAFE SYSTEM OF WORK**Electric Arc and Inert Gas Shield Welding**

Before any electrical welding commences the following procedure, along with the Company hot work procedure must be adhered to. Personnel carrying out the work must be suitably **trained and familiar with the equipment being used**.

1. When on site check if a hot work permit is required. Position suitable screens to shield others in the vicinity from the arc flash.
2. Electric arc welding may be carried out with either direct or alternating current AC/DC. The effect of an electric shock is likely to be more severe from an AC system as higher open circuit voltages are used and there may be a difficulty in releasing the grasp when under the influence of electric shock, therefore in damp conditions or if it is likely to become damp a DC plant if possible should always be used. Stand on an insulating mat whenever possible. Ensure the equipment is properly grounded.
3. Be familiar with the type of equipment being used. Check the manufacturer's manual whenever possible. Check condition and type of plant to be used, i.e. AC/DC, electric, diesel or petrol powered. Care should be taken to exhaust the fumes away from the work area or any enclosed space while using fuel powered welding plant. Remember work piece earthing is not recommended with certain types of welding set. Familiarise yourself with all the necessary safe operating procedures. Ensure you know how to switch the equipment off.
4. Inspect your equipment for defects PRIOR to use. Ensure all cables are in good condition, terminals and connections are tight and clean, and that insulation to electrode holders is sound. The work should be correctly earthed (in accordance with the equipment being used) with the earth clamp, where required, as close to the work as possible and no further away than 3 metres. All equipment should carry a current PAT certificate. Damaged or defective equipment, including gauges, should NOT be used.
5. In the case of inert gas welding only the correct apparatus, gauges etc. must be used in conjunction with the type of gas being used. Ensure hoses are defect free and tightly secured (crimped). Jubilee clips should NOT be used. Gas cylinders must be used in an upright position and secured against falling ideally by chain.
6. Ensure suitable, dry PPE is worn, i.e. steel toe cap safety boots, gauntlets (unholed), welding helmet with appropriate (UNCRACKED) filter, flame retardant overalls. For positional work a leather apron, jacket or leggings may be required according to the particular circumstances. Persons required to observe the work should also wear a welding helmet or goggles. Where practicable all skin should be covered during the welding operation.

SSW06

7. Never dip the electrode or holder in water to cool it, or lay it on the ground or work piece whilst live. Do not touch holders connected to two welding machines at the same time or touch other people with the holder or electrode. Never allow the electrode to contact earthed metalwork.
8. Hot slag/spatter should be allowed to cool slightly before chipping off. Medium impact safety goggles with clear lenses should be used during this operation. Ensure hot work pieces are handled with insulated gloves or gauntlets, preventing accidental contact by others until cool. Work pieces should be firmly clamped during the welding operation.
9. Fumes produced by welding unpainted, rust free mild steels are not generally injurious to the health, however in enclosed buildings or confined spaces mechanical fume extraction (LEV) may be necessary. When welding galvanized or stainless metals or welding with electrodes containing fluorine and inert gas shielded welding processes requires the use of an appropriate respirator.
10. Ensure trailing leads are suitably positioned away from the process and do not become tripping hazards. They should be protected from hot slag / spatter. Do not lay leads across your body whilst welding.
11. Pay attention to your positioning during welding activity so as to not become unduly over exposed to fume, spatter, conductive parts, and restricted or confined working. Take regular breaks "off arc".
12. Do not attempt to cut / repair drums or tanks suspected of having contained flammable substances unless they have been adequately cleaned out and are vented throughout the operation.
13. Isolate the electrode holder when changing the electrode. DO NOT rely on the insulation properties of your gloves to avoid electric shock.
14. When maintaining a generator engine, where used, be familiar with the manufacturer's manual.
 - Let the system cool down sufficiently
 - Disconnect the battery terminal
 - Wear the appropriate PPE particularly safety goggles and gloves when dealing with battery, radiator, fuel etc.
 - Do not remove guarding or covers unless competent to do so.

IF IN DOUBT ASK

Date: 01/01/11

SAFE SYSEM OF WORK**Flame Cutting and Welding**

Before any flame cutting or welding commences this procedure along with any hot working procedure must be adhered to. Personnel carrying out the work must be suitably trained and familiar with the equipment used.

1. Check with site management if a hot work permit / authorisation is required.
2. Ensure an adequate supply of ventilation throughout the operation. This may take the form of LEV in enclosed situations. If ventilation is poor a vapour fume respirator may be required.
3. Check condition and operation of all equipment prior to use, only correct hose must be used and must not be used for any other purpose. Jubilee clips must not be used on hose connections, or as temporary repair. Check the correct fitting, condition and operation of flame arrestor (in date), gauges and regulators fitted to the equipment. Each hose should be fitted with a non return valve at the gun. Damaged or defective equipment should NOT be used.
4. Check for hoses showing signs of perishing, leaks or splits and replace as necessary. Periodically check equipment for gas leaks using a proprietary leak detecting spray only.
5. Gas cylinders must be transported and used in an upright position in a well ventilated area, also provisions made to secure them to a suitable anchorage away from any traffic routes, sources of heat and falling objects. Cylinders should be contained in a secure storage area when not in use. Avoid using gas cylinders in poorly ventilated rooms or confined spaces.
6. Only the correct apparatus must be used in conjunction with the type of gas used. In particular acetylene pressure must NOT exceed 0.62 bar (9PSI).
7. Ensure that the hoses are positioned so as not to cause a trip hazard and that the cylinders are TURNED OFF immediately after use. Keep hoses away from flames, heat, sparks or hot spatter. The hoses must be drained and coiled away from any work activity when not in use, to prevent risk of damage and any inadvertent leaks that could become a fire or breathing risk.
8. Suitable PPE must be worn at all times, i.e. gauntlets, filter goggles or face shield, leather apron, flame retardant overalls over steel toe cap safety boots. Care and provision must be made for others not only in the immediate work area but in the direction, distance of travel of flame and/or sparks. Ensure hot work pieces are handled using thick gloves or gauntlets. Work pieces should be protected from accidental contact by others until they have cooled.
9. Remove old paint from work surfaces prior to cutting / welding since this may give rise to potentially toxic fumes particularly if the paint is lead based, otherwise an appropriate respirator will be required.

SSW07

10. Do not attempt to cut / repair drums or tanks which may have contained flammable materials. Similarly never weld / cut wheels which may have tyres fitted.
11. Shut off blowpipe when not in use. Do not leave a lighted blowpipe unattended.
12. Use the correct lighting up procedure, purging hoses before lighting and igniting the gas quickly using a spark igniter.

IF IN DOUBT ASK

Date: 01/01/11

SAFE SYSTEM OF WORK**Use of Pedestal Grinders**

Before any grinding commences this procedure, along with the Company hot work procedure must be adhered to.

1. Ensure you are trained, competent and authorised to use the machine. Do NOT undertake wheel dressing duties or changing wheels unless you have been fully trained.
2. Use the pedestal grinder in accordance with the manufacturer's operation and maintenance manual.
3. Check for and remove any flammable materials in the vicinity.
4. Inspect the machine for any obvious defects / wheel damage / guard damage and wheel security (tightness).
5. Check the stop button works and position the visor / guard effectively.
6. Where work rests are used this should be correctly adjusted to the required clearance. The work piece must be held firmly engaged with the rest during grinding.
7. Suitable PPE must be worn i.e. protective gloves, grade 1 high impact safety goggles, hearing protection and fire retardant overalls. Avoid loose fitting clothing. Avoid dust / fume inhalation. If ventilation is poor you may need a suitable mask / respirator. Ideally clean off the material surface before grinding.
8. Pay attention to the position of your body and hands and never lean / press towards the wheel with excessive force.
9. Take regular breaks from using the tool and exercise your fingers regularly. If you feel a tingling, trembling sensation in your hands / fingers when using, stop immediately and take a break!
10. Ensure other personnel remain out of the vicinity. Concentrate on your work piece and do not get distracted.
11. Clear up the area of dust after you have finished.
12. The machine must only be used for dry cutting or grinding. Never operate abrasive wheels at speeds (in RPM) in excess of that marked on the machine.
13. Do not use excessive force as this increases vibration to the hand / body. NEVER use a disc of greater diameter than that recommended for the machine / tool.

IF IN DOUBT ASK

Date: 01/01/11

SAFE SYSTEM OF WORK**Working at Height**

1. When working at height* where a risk of falling could occur then appropriate means should be taken to prevent the fall. Remember handrail protection is always preferable to use of personal fall protection equipment.
2. Work at height must be avoided whenever this is reasonably practicable.
3. Only use recognised walkways and platforms for access, never climb on plant, structures, equipment etc.
4. All work at height must be planned, supervised and carried out by personnel trained to work at height.
5. Where ladders are used, these should be footed or lashed (both stiles), set to the correct angle (1:4) and inspected for damage before use. **NO WORK SHOULD BE CARRIED OUT FROM A LADDER unless of short duration and THE RISK OF INJURY FROM FALLING IS LOW.**
6. If a scaffold is used for access, it must be erected by a competent certificated person and tagged for use.
7. If mobile elevating working platforms (MEWP) are used these must be operated by a trained certificated competent person following the company's safe system of work. A daily check should be performed prior to use.
8. Where safety harnesses and lanyards are used the wearer should be trained in their use. The harness should be of an appropriate type (restraint, retractor or arrestor type) attached to a secure and appropriate point having due regard to the length of the lanyard. A safety harness and lanyard shall always be used where it is deemed necessary to leave a recognised walkway or platform. Note harnesses and lanyards should not be more than 5 years old and you must inspect their condition before use. All equipment should carry a certificate of thorough examination (6 monthly).
9. Employees working from a man basket attached to an MEWP shall wear a restraint type safety harness and lanyard secured to the basket attachment point whenever there is a risk of falling from the basket during operation, e.g. impact or instability.
10. Ensure all tools, equipment and materials are placed where there is no risk of falling or becoming displaced especially under windy conditions.
11. The area beneath the work should be cordoned or taped off where possible. Never throw or tip anything down from height. Don't allow anyone to pass beneath.

SSW09

12. Any significant work at height will require a full method statement, risk assessment and a permit to work prior to commencement of work.
 13. No work at height should take place in significantly windy / inclement conditions.
 14. Never access a fragile roof unless by appropriate load spreading platforms and where a secondary fall protection system is in place. If the roof slope is greater than 10° crawling ladders must be used. All openings, skylights, holes in floors etc. must be protected / barriered. Where openings are temporarily covered they should be marked as “open”.
 15. Where there is a risk of falling from load spreading platforms a secondary protection system must be in place, e.g. handrails, nets, airbags, work restraint devices etc.
 16. A rescue plan in the event of emergency must be in place. Ensure you know what to do.
- * A place is ‘at height’ if a person could be injured falling from it, even if it is at or below ground level, e.g. lofts, scaffolds etc. This includes the means of access.

IF IN DOUBT ASK

Date: 01/01/11

SAFE SYSTEM OF WORK**SSW10****Use of Mobile Elevated Work Platforms (MEWP)**

1. MEWP's may only be operated by trained, certified competent personnel.
2. A safe system of work, risk assessment and method statement shall be developed for a given task prior to commencement of work.
3. The equipment must carry a current report of thorough examination of the equipment.
4. Any safeguards, weight indicators, fail safes, should be operator tested prior to operation of the equipment. Tyres should be correctly inflated.
5. Ensure the appropriate equipment is specified for use, i.e. all terrain, outriggers, etc.
6. Where outriggers are provided they should always be extended.
7. The working area should be cordoned off to prevent personnel entering. The MEWP should not be operated where there is a risk of impact from other vehicles.
8. The platform should only be operated within the conditions specified by the manufacturer.
9. The platform should not be operated in adverse weather conditions, i.e. high winds.
10. The platform should only be used on firm level ground (this may require pre-preparation).
11. The platform should not be operated close to overhead power cables or other dangerous equipment or unprotected channels / trenches etc..
12. A safety harness with a full restraint lanyard attached to the platform should be used by all operators. The harness should be less than 5 years old, in good condition and inspected before use
13. Ensure that all employees using the equipment know what to do if the machine fails with the platform in a raised position.

IF IN DOUBT ASK

Date: 01/01/11

SAFE SYSTEM OF WORK**SSW11****Welding of Lifting Eyes**

1. Use lifting eyes to the dimensions shown in the standard lifting eye detail. Each lifting eye will lift 2.4 tonnes with a safety factor of 5:1. Sufficient eyes are to be attached to both satisfy weight and stability considerations.
2. Welding rods shall conform to BS EN 549.
3. Thoroughly clean the areas to be welded with a grinder, i.e. to bright steel.
4. Ensure the eyes fit the area to be welded as closely as possible.
5. Use only dry electrodes. All electrodes should be used straight from a hermetically sealed packet if possible.
6. A bead of weld, with a minimum "leg length" of 6mm is to be deposited around the entire lifting eye in accordance with the standard detail.
7. If the lifting eye is to be tacked, the tack must be 6mm "leg length", NB; equal to the finished weld.
8. The weld should not be cooled artificially.
9. Undercut is not permitted on fillet welds.
10. Welding should not take place on steel below 5°C.
11. Lifting eyes, after use, are to be removed and scrapped.

IF IN DOUBT ASK

Date: 01/01/11

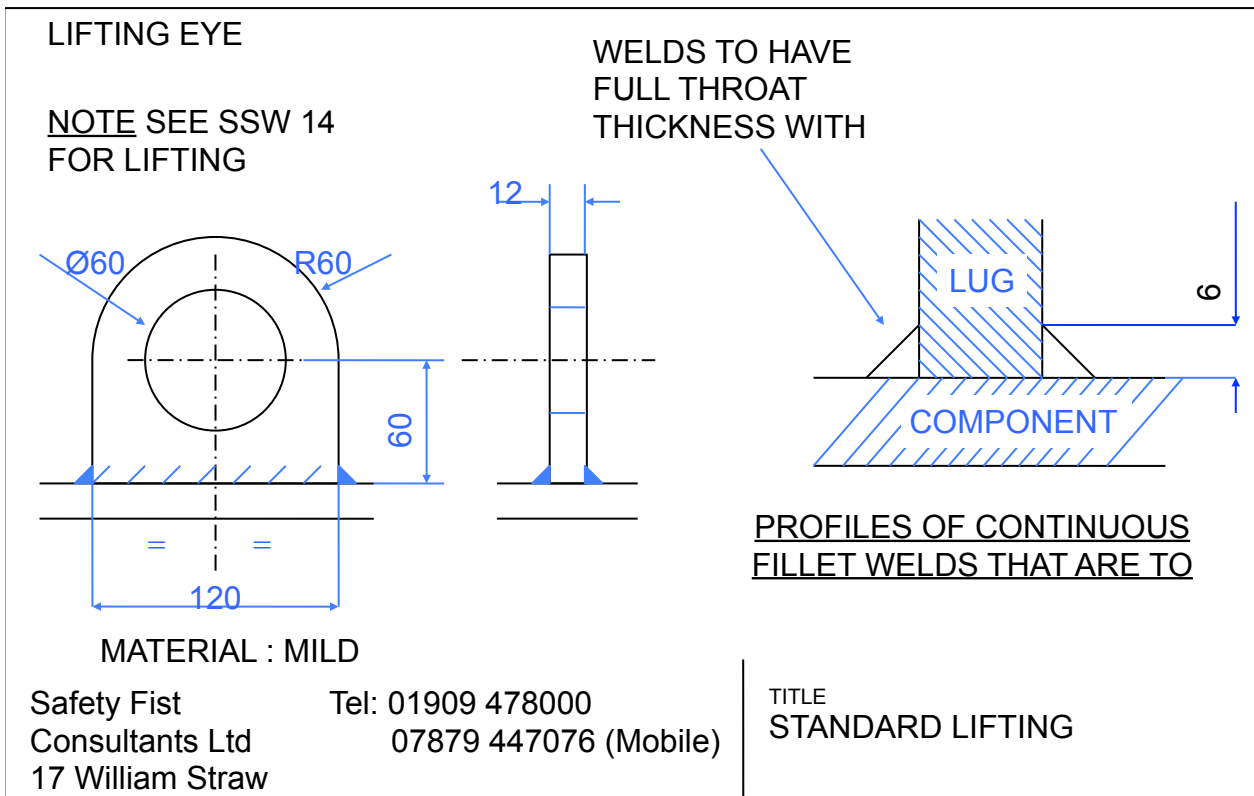

SSW12**SAFE SYSTEM OF WORK****Use of Ladders / Stepladders**

1. Check if a permit to work is required when on site.
2. Inspect ladder for damage BEFORE use. Only use a proprietary ladder (Class 1 – Industrial) of sufficient strength for its intended purpose. NEVER use a homemade / unfit or painted ladder.
3. Before positioning check for firm ground condition and proximity of overhead obstacles, i.e. power cables. Do not erect a ladder within 9 metres of overhead power cables.
4. The ladder must be secured (footing or lashing to a solid object). If the ladder is footed the person must watch the user at all times keeping both hands on the ladder stiles to arrest any sudden movements.
5. Where your feet are more than 2 metres from the floor a suitable safety restraint harness must be used securely attached to a point above your head.
6. Extend the ladder to 1 metre past the landing area and erect to 75° (1:4) angle. Where ladders are > 9metres in length adequate rest points / platforms should be provided at suitable intervals.
7. Always work on the ladder standing 5 rungs from the top. Remember this should be work of **short duration only** and where the risk of injury from falling is low. Keep your torso within the stiles. Do not overreach.
8. A ladder should only be used for the load and purpose for which it is designed (usually one person only).
9. Do not erect in front of a doorway which may be opened and make sure the foot is clear of obstructions.
10. Use the 3 point of contact method when climbing. Ensure any tools are carried in a holster and cannot become dislodged and fall. ALWAYS maintain an effective handhold at all times. Ensure your safety boots are good grip and mud free.
11. Where possible cordon off to prevent entry into an area below the ladder by unauthorised persons. Particularly attention should be paid to risk of vehicular impact erecting significant barriers where appropriate.
12. Step ladders should be suitably rigid (Class 1 – Industrial). They should not be side loaded. Over reaching should be avoided. The top step should NEVER be worked from unless designated for such a purpose, i.e. handrails provided.

IF IN DOUBT ASK

Date: 01/01/11

SAFE SYSTEM OF WORK

Use of Fork Lift Trucks

1. **NEVER operate a FLT unless you are fully trained, competent and authorised for the type of vehicle.**
2. Prior to operation a full inspection of the machine should be undertaken. This will include brakes, lights, mirrors, steering, horn, seatbelt etc. Vehicles should not be operated if any item is found to be defective. **REPORT ANY DEFECTS IMMEDIATELY.**
3. Always operate the machine wearing a seat belt, safety helmet and steel toe cap safety boots. If your vehicle overturns **ALWAYS** stay belted in **NEVER JUMP CLEAR.**
4. Do not use hand held phones or radios etc. whilst driving.
5. Ensure the flashing amber beacon and reversing beeper is correctly functioning prior to use.
6. When travelling with an FLT keep reversing to a minimum, obey the speed limit, adhere to the designated areas for use and avoid personnel routes as much as possible. **SOUND YOUR HORN AT EVERY POTENTIAL DANGER SPOT.**
7. Do not operate a FLT on terrain for which it was not designed and always in accordance with the manufacturer's handbook. Take account of slopes, corners and the centre of gravity of your load.
8. When travelling with a loaded FLT ensure the load is not stacked above the driver's eye line.
9. If a banksman is used for whatever reason ensure he remains at a safe distance from the FLT at all times. Ensure you have all round visibility when reversing. Check behind you first.
10. Loads should always be transported with their weight evenly spread between the two forks, positioned as close as possible to the carriage and to the ground. **DO NOT** attempt to lift excessive loads. **NEVER** travel over any distance with a raised load. **REMEMBER** the centre of gravity **CHANGES** as the load is lifted.
11. **NEVER** carry passengers (unless designed to do so) or attempt to lift personnel by the forks unless a purpose designed man basket is fitted.
12. Check your vehicle carries a current examination certificate as issued under the LOLER Regulations 1998.
13. Ensure there is sufficient clearance overhead before lifting a load **DO NOT** attempt this with personnel in the **IMMEDIATE** vicinity or allow personnel to walk under a raised load. **STOP** the vehicle if pedestrians enter the operating area.

14. On completion of work, park in the designated area, forks lowered and CLEAR of walkways. Apply the park brake with engine off. Shut off power on battery powered trucks, turn off gas on gas powered trucks and return keys to a place of safekeeping. **DO NOT LEAVE FLT unattended with the engine running.**
NEVER LEAVE THE KEY IN.
15. Never run over cables / flexible pipes etc. unless they are suitably protected.
Watch out for potholes.
16. Never lift a load when you are uncertain of its weight and / or it exceeds the capacity of the FLT.
17. Ensure you are fully aware of the permitted stacking height of the goods you are positioning. Never stack / move a load which appears damaged, i.e. pallet.
Report this to your supervisor.
18. Remember you will need an ALL TERRAIN vehicle for off road / poor ground conditions.
19. Take your time getting on and off your vehicle, be mindful of the weather, underfoot conditions AND other vehicles in the vicinity. Do NOT use the forks or any part of the machine for use as personal access / egress.
20. Do NOT remain stationary in workshops with the engine running for significant periods.
21. ALWAYS ensure there is adequate ventilation for exhaust fumes when using the truck indoors. Change gas cylinders outside the building.
22. Do not run gas driven trucks where there is a risk of flammable vapour, i.e. paint spraying.

IF IN DOUBT ASK

Date: 01/01/11

SAFE SYSTEM OF WORK

Use of Mechanical Band Saw

1. All operators shall be trained, authorised and competent in operation of the machine.
2. All guards / blade guides must be in position prior to operation and be correctly adjusted, as close to the work piece as possible.
3. Check stop buttons operate correctly with the machine running. Be sure the blade is NOT in contact with the work piece when the machine is started.
4. Ensure correct PPE is worn including grade 2 impact safety glasses, gloves, hearing protection, steel toe cap safety boots and mask (where necessary).
5. Check the saw blade for proper seating and tension, DO NOT operate if any damage is detected. Do not change the blade unless you have been trained to do so. Ensure the blade is pointing in the direction of the cut.
6. Ensure the work piece is securely clamped before operating the machine.
7. Avoid loose fitting clothing, jewellery and long hair (unsecured).
8. Carry out a manual handling assessment if work pieces are heavy or bulky. Utilise roller tables / lifting equipment where necessary.
9. Ensure LEV / ventilation is switched on and sufficient lighting is available to complete the task safely.
10. Take care handling swarf disposing of it to the designated receptacle using stiff gloves.
11. Ensure the immediate vicinity of the machine is kept free of tripping hazards removing any off cuts etc. at the end of the operation.
12. Never touch the moving saw blade or allow hands / fingers in close proximity.
13. Only adjust the position of the work piece with the saw switched off.

IF IN DOUBT ASK

Date: 01/01/11

SAFE SYSTEM OF WORK

Use of Solvents

1. Use the least hazardous material for the job (water based paints etc.) whenever possible.
2. Ensure you check the COSHH file and the supplier's safety data sheets along with container labels. FOLLOW THE PRECAUTIONS AND PROCEDURES REQUIRED. KNOW THE EMERGENCY PROCEDURES. Ensure suitable fire extinguishers are to hand.
3. Ensure exclusion zone is maintained around the worksite, post warning notices.
4. Wear the appropriate PPE, i.e. rubber gloves, tight fitting goggles, apron etc., as required by 2 above. If RPE is required ensure it is of the correct type and that any cartridge / filter is not spent and is fit for use. ENSURE YOU KNOW HOW TO USE IT CORRECTLY.
5. Make full use of LEV and appropriate ventilation, i.e. doors and windows to remove vapours from the work area.
6. Use minimum amount of solvent for the job, minimise evaporation by keeping lids on containers and use sealed containers for solvent contaminated waste.
7. Tidy up, do not leave solvent contaminated rags lying around. Deal with spillages promptly and ensure an adequate supply of absorbent material is available.
8. Avoid skin contact, ensure work wear covers skin, DO NOT use solvents to remove paint, grease etc. from skin. Remove rings and watches which can trap solvents against the skin. Use barrier cream where provided.
9. Do not eat or smoke in areas where solvents are being used.
10. Personal hygiene is paramount, ensure you wash thoroughly after working with solvents and before eating or smoking. Ensure overalls are regularly washed or preferably use the disposable type.
11. NEVER burn, weld, smoke etc. or use naked lights in areas which may contain solvent vapours.
12. When working in confined spaces the required risk assessment should include for necessary precaution where solvents are being used.
13. Keep only small quantities on the premises (<50 litres) and store in a metal lockable cupboard. Return solvents to the secure storage at shift end.
14. Ensure you report any possible health problems to your supervisor, i.e. skin rashes, sore eyes, wheezing, tight chest etc.

IF IN DOUBT ASK

Date: 01/01/11

SSW16**SAFE SYSTEM OF WORK**

Operation of Mobile Plant

1. Vehicles will not be operated without authorisation from the site management.
2. All operators will hold a current licence for the category of plant they are operating including manoeuvring into the workshops or for maintenance purposes.
3. All plant will be driven, operated and parked within the designated routes and areas defined.
4. All mobile plant must be fit for purpose and carry any appropriate paperwork in the cab.
5. Plant will be inspected and brake tested prior to use and any significant defects brought to the attention of the Company Director.
6. DO NOT OPERATE any plant which has defective brakes, steering or reversing aids.
7. Operate the plant in accordance with manufacturer's instructions, ensuring the flashing amber beacon is on and seat belt is fastened.
8. Buckets shall NOT be used for lifting equipment or personnel.
9. Passengers may only be taken if a fixed seat and restraint is provided for the purpose.
10. Obey all speed limits, signs and one way systems.
11. Do NOT operate a mobile phone or radio whilst the plant is moving.
12. If you need to operate the equipment in a restricted / congested area, adjacent to excavations or lagoons or where pedestrians have ready access ensure a trained banksman / signaller is utilised who is wearing suitable high visibility clothing. In these circumstances a permit to work may be needed.
13. Do NOT climb onto your machine for any purpose, i.e. maintenance unless a fixed / appropriate means of access is provided.
14. Do NOT leave your machine unattended with the engine running. Ensure key security at all times.
15. Any maintenance work should only be undertaken with appropriate authorisation. This will be done in a designated area, on suitable, level and well lit ground. The machine should be properly isolated from movement and warning notices posted as necessary.

SSW16

16. Vehicles should only be towed using approved towing hitches and purpose made chains / ropes (see SSW).
17. Care should be taken when jump starting any vehicle (see SSW).
18. Do not operate your vehicle outside its intended limits. Do not operate / allow it to be overloaded / incorrectly loaded.

IF IN DOUBT ASK

Date: 01/01/11

SAFE SYSTEM OF WORK**SSW17****Unloading / Loading of Steel Stock and Equipment**

1. Ensure you are trained, competent and authorised to use a fork lift truck. Obtain Client permission when driving at site.
2. Ensure the loading route / area is free from obstacles and personnel not required for the loading operation.
3. If reversing of the trailer wagon is required a competent banksman should be used wearing high viz clothing. Only the banksman should advise the driver when the operation is complete and it is safe to move off.
4. Ensure the weight of materials lifted is known and within the capacity of the FLT, chains, lifting attachments etc. being used. Select lifting accessories suitable for the task.
5. The loading operation should be undertaken by competent persons. Ensure you are trained in lifting / slinging operations before undertaking the work. Ideally two persons are required.
6. The operation should be supervised by a competent person. THE LORRY DRIVER SHOULD NOT make any key decisions.
7. Only personnel required for the loading or unloading operation should be allowed in the vicinity.
8. If chains, clamps, slings etc are utilised. Inspect them for defects prior to use and check that they carry a current certificate of thorough inspection.
9. Ensure your fork lift trucks or mobile cranes etc. carry a current certificate of thorough inspection and the relevant daily checks have been undertaken.
10. Check the load before moving it off or onto the vehicle: -
 - Make sure it is secure.
 - Do not allow unstable loads to tip and roll off the vehicle
 - Do not drag the load off/on the vehicle
 - Do not stand on the load once it has been positioned by the lifting equipment
 - Ensure the driver is well away from the load being lifted.
 - Do not split loads which have not been correctly spaced on packs.
11. Ensure the load is attached correctly to restrict any potential movement. Do not lift / carry it over the heads of any personnel.

SSW17

-
12. Only allow personnel who need access to the vehicle for loading onto it. It should be accessed where possible by steps, loading gantry otherwise it should be from the front around the headboard. NEVER via the sidebars. The time on the back of the vehicle should be minimised. DO NOT jump down from the back of vehicles. DO NOT stand with your back to the lorry / trailer edge. Do NOT use the forks or any part of the machine for use as personal access / egress.
 13. Ensure there is sufficient lighting to undertake the task being mindful of underfoot conditions, e.g. wet, frosty etc.
 14. Ensure appropriate PPE is worn including safety helmet (where site rules apply), gloves, high visibility top and steel toe cap safety boots.
 15. Particular attention should be paid to your personal positioning to ensure you are not in danger of falling or being struck by moving or falling loads/ vehicles.
 16. Always ensure you work facing the open edge of the vehicle.

IF IN DOUBT ASK

Date: 01/01/11

SAFE SYSTEM OF WORK**SSW18****Lone Working**

1. Ensure signing in procedure is followed and initial contact is made when working at site.
2. A permit to work is required prior to work commencement.
3. Only routine low risk work should be undertaken.
4. Work in confined spaces, at significant height or electrical work shall NOT be undertaken.
5. A risk assessment for the work should be carried out and the control measures identified, communicated and adhered to.
6. An adequate means of communication should exist, i.e. mobile phone and regular, agreed contact maintained with the designated, off site person.
7. Personnel undertaking lone working should be suitably trained and experienced in the work being undertaken and medically fit and suitable to work alone.
8. Wherever possible periodic supervisory visits should be undertaken to check on worker well being.
9. If it is not possible to undertake regular checking of persons working alone consideration should be given to the use of automatic warning devices (movement detectors).

IF IN DOUBT ASK

Date: 01/01/11

SAFE SYSTEM OF WORK**SSW19****Use of Hand Held Vibrating Tools**

1. Ensure the appropriate tool is being used for the job in hand and that the chisels, points etc. are sharp.
2. Use the equipment in accordance with manufacturer's data and training received. Do NOT exceed the maximum time specified for use at any one time,
3. Inspect the equipment for fault and correct operation before use. A poorly maintained / balanced item of equipment increases the level of vibration suffered.
4. Wear the appropriate PPE which will always include safety helmet, medium impact safety glasses, steel toe cap safety boots and most importantly warm gloves.
5. Do not smoke before and during the planned activity and take regular hot food and drink.
6. Use the minimum amount of force at all times to complete the work.
7. Regularly massage the fingers and exercise the upper torso, arms, neck, back etc.
8. Use the equipment for short duration spells only taking regular breaks.
9. Ensure your hands are warm and remain so throughout the activity.
10. STOP immediately if any tingling sensation is felt in your hands or fingers.

IF IN DOUBT ASK

Date: 01/01/11

SAFE SYSTEM OF WORK

Use of Overhead Cranes

1. Ensure you are authorised to operate the crane. Wear your PPE at all times particularly steel toe cap safety boots, safety helmet and gloves.
2. Only a trained and competent person may operate, lift and sling with the crane. Ensure you plan the lifting operation thoroughly. Remember you are in charge of all the safety aspects of the lift.
3. Check the crane and accessories carry current certificates of thorough examination and check for any defects, damaged pendants, broken safety catches, kinks etc. **Ensure** the emergency stop works.
4. Never drag the load always bar it off to aid movement and use turning bars to move loads on stands and stillages.
5. You the lifter / slinger must: -
 - Assess the weight of the load
 - Choose the accessory most suitable for lifting and ensure it is **undamaged** and has sufficient capacity to lift the load. Never exceed the safe working load.
 - Always sling with two chains forming an equal sided triangle.
 - Never lift with the top flange only.
 - Check the anticipated path of the load to make sure that it is not obstructed (particularly by personnel).
 - Prepare a suitable place to set down the load (using packs).
 - Ensure a clear pathway for walking in the long travel direction, face forward when walking and remain focused on the task.
 - Fit the accessory to the load (using appropriate method).
 - Make the lift, a trial lift may be necessary to confirm the centre of gravity of the load having clearly marked this position with chalk on the top flange. If the load is to be steadied keep hands to the outside face.
 - Do not allow the load to swing.
 - Release the slings / accessory.
 - Clear up
6. When more than one item is lifted (stacked) components should be interlocked. Take care not to “hide” smaller components inside larger ones. Do not carry excessively loose components on top of others.
7. Splitting of interlocked items should be carried out using an appropriate size plate clamp (plate clamps must NOT be used on tapered flanges).
8. The overhead crane shall NOT be used for a working platform for any reason and NEVER weld components still attached to the crane.

SSW20

9. ~~When using wheeled “walking” cranes maintain safe personal positioning of your feet in relation to the wheels.~~
10. Care should be taken to NOT lift over persons or walkways. Never obstruct walkways or the tracks of wheeled cranes when setting components down.
11. When the crane is not in use ensure hooks are hooked back into the ring (follow this procedure if traversing crane without a load) and take care not to bump the stops or adjacent crane positions.
12. When components require the use of special lifting points the Engineering Manager will advise. Never set down “steel on steel”, always use appropriate spacers / packs.
13. When hollow sections are lifted as a bundle ensure each end is secured with wire / straps prior to lifting.
14. Particular attention should be paid to any live conductors running the length of the building when slinging and operating the crane. Electricity must be isolated for maintenance purposes.
15. Always maintain safe personal positioning of torso, hands and feet when slinging, setting down and turning work pieces.

IF IN DOUBT ASK

Date: 01/01/11

SAFE SYSTEM OF WORK**SSW21****Use of Combination Metalworking Machines**

1. No workstation at the combination machine should be operated unless you have been trained, authorised and are fully familiar with the equipment.
2. Before the equipment is used all guarding should be checked for position and function and E stops tested for effectiveness.
3. Ensure foot shrouded machine controls are correctly functioning.
4. Ensure PPE is worn, notably safety goggles and gloves.
5. Use roller tables for supporting work pieces and get help to position it if weight is greater than 25kg.
6. Do not offer material into any workstation for which it is not designed to cope with, i.e. thickness, geometry, type.
7. Operate the machine only in accordance with manufacturer's instructions and with all guards (including rear guards) in place.
8. Ensure machine tools / gaps are set at the minimum practicable gap and avoid using hands / fingers in the immediate vicinity of moving stocks / blades / tools etc.
9. Ensure the work area remains clean and tidy, remove off cuts immediately, taking care with sharp edges.
10. Ensure there is an appropriate level of lighting to carry out the task in hand.

IF IN DOUBT ASK

Date: 01/01/11

SAFE SYSTEM OF WORK

Use of Scaffolding / Mobile Towers

1. Only trained, authorised and competent persons may erect, dismantle and modify fixed and mobile scaffolds.

Fixed Scaffold

2. No employees are authorised to erect fixed scaffolds, this must be undertaken by a scaffold company.
3. Fixed scaffolds must be inspected every seven days and a record made in the register kept at site.
4. Before using a fixed scaffold check to see it looks O.K. and: -
 - Has been inspected in last seven days
 - The ladder is defect free and lashed off
 - All handrails, kickboards etc. are in place
 - The working platform has all its boards in place and are not split etc.
 - Scafftag is attached
 - All feet appear stable and on good ground.
5. Ensure any tools and equipment you use cannot fall from the scaffold and injure others.
6. Ensure you do not overload the scaffold with plant / materials. The foreman / supervisor will advise.
7. Do not use the scaffold if it is excessively windy or your cursory inspection has revealed a defect. Inform the supervisor.
8. NEVER modify a scaffold even in a minor way, contact the scaffold company to do this for you.
9. Do NOT use the scaffold if you have any reason to suspect its competence, i.e. struck by vehicles / plant, subjected to heavy winds etc. Inform your supervisor.

Mobile Scaffold Towers

10. Ensure you have been trained in the proper erection of the equipment.
11. Follow the manufacturer's instructions, particularly in terms of height / stability.
12. Do NOT place yourself at risk from falling during the erection process.

SSW22

13. Ensure the ladder is climbed on the inside of the tower to avoid pulling the tower over.
14. Ensure all the handrails, kickboards, braces etc. are positioned before using it.
15. Only erect the tower on suitable, firm and level ground and that the wheel locks are applied before using it.
16. Beware of overhead obstacles, power cables etc.
17. Never move the tower whilst personnel are on it.
18. Ensure it cannot be struck by vehicles, plant and equipment, post warning signs, cones, barriers etc. if necessary.
19. ALWAYS inspect it visually before you use it.
20. Secure tools and equipment against falling and position warning signs / barriers to notify personnel on foot in the vicinity.

IF IN DOUBT ASK

Date: 01/01/11

SAFE SYSTEM OF WORK

Manoeuvring Steel Stock / Components into Workshop Using FLT

Before any manoeuvring of steelwork is undertaken the following procedure, along with other relevant company SSW must be consulted and adhered to.

1. Whenever practicable steel stock should be ordered in pre-cut lengths. Where this is not possible consideration should be given to cutting steel to length prior to moving it into the workshops.
2. The area in the vicinity of the manoeuvring should be cleared of surplus personnel, stored materials, debris etc.
3. Banksmen / sentries should be positioned to halt the approach of pedestrians, non employees and other vehicles using the site. The activity should be supervised.
4. The condition of the ground, surfaced areas should be checked prior to the operation to ensure suitability for a counterbalanced FLT. Any wet areas should be cleared up / dispersed to prevent personnel slipping etc.
5. Care should be taken with slinging of the components to ensure: -
 - The FLT is not overloaded / becomes unstable
 - The load cannot slip through any chains used.
 - Personnel aiding / steering / guiding the components are not placed at risk from moving vehicles / falling materials due to poor personal positioning.
6. Where roller tables are available these should be used to make the final positioning manoeuvre of the component into the workshops where practicable.
7. Care should be taken in slinging the components to roller tables to ensure they cannot fall off.
8. All personnel in the operation must wear suitable PPE, including safety footwear, gloves and high viz coveralls or vest.
9. All personnel involved should be demonstrably competent to operate FLTS and lift and sling components.
10. Where possible lifting eyes should be welded / attached to components in accordance with the Company SSW to aid slinging activities.

IF IN DOUBT ASK

Date: 01/01/11

SAFE SYSTEM OF WORK

Use of Guillotine

1. All operators shall be trained, authorised and competent in the operation of the machine.
2. All guards must be in position prior to operation and be correctly adjusted. Interlocked guards to the rear of the machine should also be checked for function.
3. Check operation of E stops and foot control with machine running.
4. Ensure correct PPE is worn including goggles and gloves (high quality).
5. Use push sticks where appropriate.
6. Ensure the cutting edges are maintained and checked for wear or chipping prior to use. Poor / unsharp edges may cause unpredictable movement of work pieces.
7. Carry out a manual handling assessment if work pieces are heavy or bulky. Utilise roller tables / lifting equipment where necessary.
8. Ensure there is adequate lighting to complete the task safely.
9. Do not access the rear of the machine whilst it is operating.
10. Ensure the machine is only used to cut the type, thickness and range of materials for which it is designed.

IF IN DOUBT ASK

Date: 01/01/11

SSW25**SAFE SYSTEM OF WORK**

Operation of Peddinghaus FPB1500 (Plasma Cutter)

1. Do not operate the machine unless you are fully trained, competent and authorised to do so.
2. Ensure you check the emergency stops and safety light curtains are correctly functioning at the start of the shift and after any significant break in use.
3. Never operate the machine with defective light curtains, e-stops or barriers.
4. Wear your PPE (gloves and safety boots) when operating the machine and in particular the appropriate filter goggles.
5. Ensure the plasma arc shield is in place before starting up.
6. Never allow anyone to remain inside the light curtains when the machine is operated.
7. Do not enter the area to the off side of the machine during operation (opposite side to the CNC panel), as there are no operational light curtains.
8. Maintain safe personal positioning at all times. Never place your hands within 300mm of the working torch head or punch.
9. When changing punches or adjusting the cutting torch ensure the machine is switched off and an appropriate emergency stop has been activated.
10. Never carry out maintenance activities unless the machine has been fully locked out using the published personal lockout procedure.
11. Do not operate the machine unless the extraction system is correctly functioning.
12. Ensure the area around your machine is well lit and maintained in a clean and tidy state.
13. Never leave the machine unattended when in use.

IF IN DOUBT ASK

Date: 01/01/11

SAFE SYSTEM OF WORK

Operation of Shot Blasting Equipment

1. Do not operate the machine unless you are fully trained, competent and authorised to do so.
2. Ensure you check the emergency stops are correctly functioning at the start of the shift and after any significant break in use.
3. Never operate the machine with defective e-stops or barriers.
4. Wear your PPE (hearing protection, gloves and safety boots) when operating the machine and in particular grade 1 impact safety goggles.
5. Ensure the extraction system is switched on before use.
6. Ensure you lift shot bags using the kinetic method of lifting (bent legs, straight back).
7. Keep the shot bucket emptied, wear a dust mask for this operation.
8. Maintain safe personal positioning at all times. Never place your hands within 300mm of the powered roller / transport system.
9. Do not climb inside / on top of the machine unless you have been trained and are familiar with the internal operation of the machine.
10. Never carry out maintenance activities unless the machine has been fully locked out using the published personal lockout procedure.
11. Use the proprietary access for climbing onto the machine only (this includes the external extraction system).
12. Ensure the area around your machine is well lit and maintained in a clean and tidy state. Remove any flammable materials in the vicinity, e.g. blocks of wood. Sweep up shot regularly.
13. Do not leave the machine unattended when in use.
14. Never climb over the roller sets whether operational or not or walk on moving beams to sweep off shot.
15. Beware of fork lift trucks operating in the area. Wear your high viz tops at all times.

IF IN DOUBT ASK

Date: 01/01/11

SAFE SYSTEM OF WORK

Operation of Kaltenbach Circular Sawing Machine

1. Do not operate the machine unless you are fully trained, competent and authorised to do so.
2. Ensure you check the emergency stops and safety light curtains are correctly functioning at the start of the shift and after any significant break in use.
3. Never operate the machine with defective light curtains barriers, e-stops or barriers.
4. Wear your PPE (hearing protection, gloves and safety boots) when operating the machine and in particular grade 1 impact safety goggles (in the vicinity of the shotblaster).
5. Ensure the cutting fluid is activated and adjusted to a suitable flow before starting up.
6. Never allow anyone to remain inside the light curtains / barriers when the machine is operated.
7. Do not remove machine off cuts greater in weight than can be handled by suitable kinetic lifting techniques.
8. Maintain safe personal positioning at all times. Never place your hands within 300mm of the saw blade, clamps etc. during operation.
9. When changing saw blades see the appropriate safe system of working.
10. Never carry out maintenance activities unless the machine has been fully locked out using the published personal lockout procedure.
11. Check the chippings tray and empty it regularly using the kinetic method of lifting.
12. Ensure the area around your machine is well lit and maintained in a clean and tidy state.
13. Do not leave the machine unattended when in use.

IF IN DOUBT ASK

Date: 01/01/11

SSW28**SAFE SYSTEM OF WORK**

Operation of Peddimat TDK 1000/3C Drilling Machine

1. Do not operate the machine unless you are fully trained, competent and authorised to do so.
2. Ensure you check the emergency stops and safety light curtains are correctly functioning at the start of the shift and after any significant break in use.
3. Never operate the machine with defective light curtains, e-stops or barriers.
4. Wear your PPE (gloves and safety boots) when operating the machine.
5. Never allow anyone to remain inside the safety barriers when the machine is operated.
6. Maintain safe personal positioning at all times. Never place your hands within 300mm of the working head.
7. When changing drill bits ensure the machine is switched off and an appropriate emergency stop has been activated.
8. Never carry out maintenance activities unless the machine has been fully locked out using the published personal lockout procedure.
9. Check the swarf tray and empty it regularly using the kinetic method of lifting.
10. Ensure the area around your machine is well lit and maintained in a clean and tidy state.

14. Never leave the machine unattended when in use.

IF IN DOUBT ASK

Date: 01/01/11

SAFE SYSTEM OF WORK

Operation of FDB2 (Oxy/acetylene cutter and hole driller)

1. Do not operate the machine unless you are fully trained, competent and authorised to do so.
2. Ensure you check the emergency stops and safety light curtains are correctly functioning at the start of the shift and after any significant break in use.
3. Never operate the machine with defective light curtains, e-stops or barriers.
4. Wear your PPE (gloves and safety boots) when operating the machine and in particular heat resistant gloves when handling hot plates or slag.
5. Never allow anyone to remain inside the light curtains / barriers when the machine is operated.
6. Do not remove plates greater in weight than can be handled by suitable kinetic lifting techniques. Use the overhead crane.
7. Maintain safe personal positioning at all times. Never place your hands within 300mm of the working torch head or drill.
8. When changing drills or adjusting the cutting torch ensure the machine is switched off and an appropriate emergency stop has been activated.
9. Check the slag tray and empty it regularly using the kinetic method of lifting.
10. Never carry out maintenance activities unless the machine has been fully locked out using the published personal lockout procedure.
11. Do not operate the machine unless the extraction system is correctly functioning.
12. Ensure the area around your machine is well lit and maintained in a clean and tidy state.
13. Never leave the machine unattended when in use.

IF IN DOUBT ASK

Date: 01/01/11

SAFE SYSTEM OF WORK**SSW301****Hand Held Disc Grinding and Cutting**

Before any grinding or disc cutting commences this procedure, along with the Company hot work procedure must be adhered to.

14. When on site check with the designated person if a hot work permit / authorisation is required.
15. With the plug disconnected check equipment in accordance with the Company procedure for use of electrical tools and equipment and also check for correct disc, i.e. grinding/cutting. Pay attention to the dimensions of the disc, the mounting hole diameter must fit the mounting flange, reducers, spacers or adapters must not be used. The auxiliary handle must be fitted as must the DISC GUARD.
16. Suitable PPE must be worn i.e. abrasion resistant protective gloves, high impact safety goggles, suitable hearing protection and fire retardant overalls. Avoid loose fitting clothing. Avoid dust / fume inhalation. If ventilation is poor you may need a suitable mask / respirator. Ideally clean off the surface before grinding.
17. Use the equipment in accordance with the manufacturer's instructions and your training. Ideally the tool should be fitted with an anti vibration head.
18. Take regular breaks from using the tool and exercise your fingers regularly. If you feel a tingling, trembling sensation in your hands / fingers when using, stop immediately and take a break!
19. Apply the machine to the work piece only when switched on, and allow to run up to optimum speed without load. Do not use damaged or deformed grinding/ cutting discs. Check the discs have not been over tightened.
20. The machine must only be used for dry cutting or grinding. Check the disc is marked with a speed less than the maximum rpm of the tool.
21. Care must be taken to prevent damage to the cable and creating of tripping hazards, by ensuring the cable is always sensibly positioned away from the area to be cut or ground.
22. Pay attention to the direction of rotation, always hold the machine so that sparks and grinding dust direct away from the body, also taken into account other persons that may be endangered.
23. Never use a cutting disc for grinding. Do not subject cutting discs to side pressure. Do not use excessive force as this increases vibration to the hand / body. NEVER use a disc of greater diameter than that recommended for the machine / tool.

24. ~~Always switch off the machine and allow to come to a complete stop before~~ laying it to rest.
25. Ideally do not smoke immediately prior and during the grinding operation (this practice reduces blood circulation). Don't use the grinder with cold hands, get them warmed up before you start work.
26. Do not use hand held electrical equipment in wet conditions.
27. Do not use in enclosed spaces unless there is sufficient ventilation.

IF IN DOUBT ASK

Date: 01/01/11

SAFE SYSTEM OF WORK_

Use of PPE

Remember all work is likely to require the wearing of some item of personal protective equipment (PPE) particularly use of any work equipment / machinery / contact with substances etc.

- 1) Always consult the risk assessment for the work activity if you are unsure what type of PPE is required to be worn.
- 2) Ensure you have received training, information and instruction on how to use your PPE.
- 3) Maintenance work will generally require the wearing of coveralls, safety footwear and class 2 high viz vests / jackets at all times.
- 4) Contacting hazardous substances normally requires the wearing of appropriate goggles and gloves. Consult the COSHH register if you are unsure.
 - Gloves to protect against oils, lubricants, solvents should be latex, vinyl, PVC or nitrile.
 - Goggles to protect against liquid splashes should be to EN166-3 standard.
- 5) Where there is a risk of projectiles, e.g. hammering activities, safety goggles should be to Grade 1 impact standard. Where there is a risk of cutting, trapping or crushing, abrasion resistant gloves should be selected.
- 6) Welding activities require goggles / shields with filters to BSEN169 and 175. Ensure you have the correct one.
- 7) Ensure your items of protective equipment are compatible with each other, e.g. the safety glasses do not impair the effectiveness of hearing protection.
- 8) Look after your PPE, ensuring: -
 - a. Safety helmets are changed regularly (date stamped)
 - b. Class 2 High viz clothing remains visible (not dirty)
 - c. Disposable ear plugs are used once only and inserted with clean hands.
 - d. Coveralls are regularly cleaned and removed immediately if contaminated.
 - e. It remains in efficient working order to do its job.
- 9) Ensure you make the correct choice of equipment particularly in respect of: -
 - a. Hearing protection
 - b. Respiratory protectionAsk if you are in doubt.

SSW31

- 10) If you need to use:
- a. Safety harnesses and lanyards
 - b. Respiratory equipment
- Ensure you are trained, authorised and competent in its use.
- 11) Store items of PPE properly, if you lose it get a replacement promptly. REPORT DEFECTS upon discovery and get another set / item etc.
- 12) Never use old, dirty, worn out, hence defective PPE.
- 13) Obey all mandatory signs requiring the use of PPE at all times.
- 14) Always dispose of damaged, expired, contaminated PPE in the appropriate manner ensuring others cannot inadvertently use it.

Remember PPE should be used as a 'last resort', the hazard we are at risk from still exists and we should be trying to eliminate it in the first instance.

IF IN DOUBT ASK

Date: 01/01/11

SSW32**SAFE SYSTEM OF WORK**

Use of Magnetic Drills

1. With the power source disconnected ensure the correct cutter is fitted and that the retaining screws are secured. Continuous use may cause screws to vibrate loose. Check this.
2. Do not use on the same structure when arc welding is in progress. DC current will earth back through the magnet and cause damage.
3. Always secure the machine with the safety strap before operation commences
4. Suitable PPE must be worn, i.e. medium impact safety goggles, gloves and steel toe cap safety boots.
5. Tie back or remove any loose items of clothing and remove any jewellery etc. that may become entangled with the rotating parts.
6. With a gloved hand and power off remove any swarf that might have gathered around the cutter / arbour and work piece, in between drilling operations.
7. Cutting fluid should be used at all times, ensuring surplus fluid does not enter the motor casing.
8. Use of excessive pressure may result in damage to the machine and / or cutter and injury to the operator. Always ensure that the slug has been ejected from the previous hole before commencing to cut the next.
9. If the machine is to be used above waist height ensure a suitable manual handling technique is employed to position it. This may require assistance or the use of lifting equipment.
10. Ensure personnel do not wander through the area below your drilling operation.

IF IN DOUBT ASK

Date: 01/01/11

SAFE SYSTEM OF WORK**SSW33****Use of Radial Arm / Pedestal Drill**

1. All operators shall be trained, authorised and competent in operation of the machine including its safety features.
2. Ensure a brief inspection of the machine is undertaken BEFORE use. DO NOT operate defective equipment. Do not use bent, damaged or blunt bits.
3. REMEMBER any injury is most likely to occur during the initial drilling of the work piece therefore: -
4. Check the stop button operates correctly with machine running along with any vertical trip device.
5. Ensure the chuck guard is correctly adjusted and the work piece is adequately clamped and the drill is tight.
6. Ensure the chuck key is removed prior to operating the drill.
7. Ensure suitable PPE is worn, this will include grade 1 impact wrap around safety glasses, steel toe cap safety boots and coveralls with close fitting cuffs and sleeves. Avoid using loose GLOVES in the vicinity of the chuck, these should be tight fitting abrasion resistant gloves.
8. If noise levels during drilling is excessive (> 85dBA) wear suitable hearing protection.
9. Do not wear loose fitting clothing, jewellery or long hair (unsecured).
10. Ensure the flow of cutting fluid where used is not excessive and ventilation is adequate.
11. Ensure the immediate vicinity of the machine is kept free of tripping hazards and is adequately lit with sufficient manoeuvring room to undertake the task.
12. If the work piece weighs more than 25kg get assistance with the lifting.
13. Remove any swarf with the power switched off, using a gloved hand only.

IF IN DOUBT ASK

Date: 01/01/11

SAFE SYSTEM OF WORK_

Unloading / Loading of Steel Stock and Equipment with Overhead Crane

1. Ensure you are trained, competent and authorised to use a crane.
2. Ensure the loading route / area is free from obstacles and personnel not required for the loading operation.
3. If reversing of the trailer wagon is required a competent banksman should be used wearing high viz clothing. Only the banksman should advise the driver when the operation is complete and it is safe to move off.
4. Ensure the weight of materials lifted is known and within the capacity of the crane, chains, lifting attachments etc. being used. Select lifting accessories suitable for the task.
5. The loading operation should be undertaken by a minimum of two competent persons where practicable. Ensure you are trained in lifting / slinging operations before undertaking the work.
6. The operation should be supervised by a competent person. THE LORRY DRIVER SHOULD NOT make any key decisions.
7. Only personnel required for the loading or unloading operation should be allowed in the vicinity.
8. If chains, clamps, slings etc are utilised. Inspect them for defects prior to use and check that they carry a current certificate of thorough inspection.
9. Ensure the crane and accessories carry a current certificate of thorough inspection.
10. Check the load before moving it off or onto the vehicle: -
 - Make sure it is secure.
 - Do not allow unstable loads to tip and roll off the vehicle
 - Do not drag the load off/on the vehicle
 - Do not stand on the load once it has been positioned by the lifting equipment
 - Ensure the driver is well away from the load being lifted.
11. Ensure the load is attached correctly to restrict any potential movement. Do not lift / carry it over the heads of any personnel.

SSW34

12. ~~Only allow personnel who need access to the vehicle for loading onto it. It~~ should be accessed where possible by steps, loading gantry otherwise it should be from the front around the headboard. NEVER via the sidebars. The time on the back of the vehicle should be minimised. DO NOT jump down from the back of vehicles. DO NOT stand with your back to the lorry / trailer edge.
13. Ensure there is sufficient lighting to undertake the task being mindful of underfoot conditions, e.g. wet, frosty etc.
14. Ensure appropriate PPE is worn including safety helmet, gloves, high visibility top and safety footwear.
15. Particular attention should be paid to your personal positioning to ensure you are not in danger of falling or being struck by moving or falling loads/ vehicles.
16. Always ensure you work facing the open edge of the vehicle.

IF IN DOUBT ASK

Date: 01/01/11

SAFE SYSTEM OF WORK**SSW35****Use of Trestles and Stands**

1. Check the trestle / stand (frame) for any signs of damage or disturbance before use. Pay particular attention to the feet and support points.
2. Set the frame on a firm, rigid footing. Do not block through routes and walkways.
3. Ensure the frame is capable of safely supporting the component it is to accept.
4. Ensure any necessary fixing devices / clamps or restraints are appropriately positioned to the work piece.
5. Do not position the work piece on the frame by FLT or overhead crane unless you are trained, competent and authorised to undertake such duty.
6. Take care when rotating work pieces to ensure no instability or uncontrolled movement ensues.
7. Follow safe personal positioning practice when positioning, moving or rotating work piece paying particular attention to fingers / hands and arms. Never place any part of your body beneath the work piece if possible.
8. Ensure unauthorised personnel remain outside the danger area whilst work pieces are being positioned on the stands.
9. Always wear the appropriate personal protective equipment when using frames and in particular when carrying out work on a supported component. This will include steel toe cap safety boots, stiff gloves, hearing protection if noise levels are at or above 85dBA (if you have to shout to make yourself heard.)
10. If you are carrying out hammering, grinding or brushing type activities ensure you wear grade 1 protection, high impact, safety goggles.
11. You may also need to consider the use of an appropriate dust mask if you are creating any significant particles / dust etc.
12. Ensure components are sufficiently cool before handling them directly.
13. Always report any problems / defects with the equipment before you use it.

IF IN DOUBT ASK

Date: 01/01/11

SAFE SYSTEM OF WORK**SSW36****Entry into Electrical Panels (Resetting Overloads only)**

You may only enter electrical panels if you are trained, competent and authorised to access the equipment.

1. Use the main panel isolator whenever possible.
2. ASSUME ALL WIRES / COMPONENTS ARE LIVE.
3. Be aware of the environment, check it is not wet or there is a risk of splashing etc.
4. Keep “others” away from the vicinity.
5. Ensure there are no metallic objects nearby.
6. Do not wear any metal jewellery / watches etc.
7. Ensure clothing, coveralls etc. are tight fitting and any long hair is tied back.
8. Ensure your hands are dry / wear insulating gloves (BSEN 6093:1993).
9. Ensure you have sufficient light for the task.
10. Do not allow the door to swing back.
11. Stand on rubber matting whenever possible.
12. Remain at arms length away whenever practicable.
13. Check for any signs of trouble, looking for obvious faults (visually) inside the panel. If there are, close the panel and call for an electrician.
14. Don't guess what the problem is, if you don't know or are unsure, close the panel, call for an electrician.
15. **Do not** touch any part of the panel “internals” including metal surfaces / screws etc.
16. Use only one hand and try to keep one hand in your pocket.
17. ALWAYS use a short insulated push rod to “set” the overload.
18. If the overload button kicks back out immediately call an electrician. DO NOT PERSEVERE.
19. Ensure no one can be injured when plant / equipment kicks back up.
20. Secure the panel when you have finished.

IF IN DOUBT ASK

Date: 01/01/11

SAFE SYSTEM OF WORK**SSW37****Use of Hazardous Substances**

Remember all substances have a potential to be hazardous, the most effective route of entry into your body is via breathing vapour, fumes etc. Therefore before using any substance: -

1. Ensure you know the safe method of handling it and what to do if you spill it, contact it etc.
2. Consult the COSHH register and identify the safe working precautions. If this is not available, instructions are usually printed on the tin, container etc.
3. Always adhere to the safety measures stated, these will usually involve the use of PPE and / or ventilation and keeping clear of ignition sources, e.g. welding, smoking etc.
4. Ensure you wear the stated PPE, if you are not sure ask.
5. Ensure there is sufficient ventilation if you are working indoors or inside equipment.
6. Report any defective equipment including PPE.
7. If you 'contact' the substance consult the safety information and ensure any contaminated coveralls, gloves etc. are removed.
8. Spillages should be reported immediately and after consultation with the appropriate data sheet or 'can' information clean it up.
9. Dispose of any spillages in the appropriate manner. This will normally mean in a hazardous waste skip / receptacle.
10. Do not decant substances into other unmarked containers.
11. Remember some substances are hazardous to the environment and therefore must not be allowed to enter drainage systems, water courses etc.
12. Ensure you return hazardous substances to their lockable store at the end of use and at shift end.

IF IN DOUBT ASK

Date: 01/01/11

7.0 APPLICABLE PRINCIPAL LEGISLATION

7.1 The Company Safety Advisor will routinely identify new legislation and report through the safety committee.

.2 As new statutory requirements are released the company will ensure the relevant applicable legislation is submitted to the list below.

.3 The Company will ensure all relevant legislation is evaluated and reflected in the Company Safety Manual as appropriate.

.4 The following legislation is applicable to the Company. The list is not exhaustive.

- 1) Health and Safety at Work etc. Act 1974 (HSWA)
- 2) Management of Health and Safety at Work Regulations 1999 (MHSWR)
- 3) Provision and Use of Work Equipment Regulations 1998 (PUWER) (as amended)
- 4) Pressure Systems Safety Regulations 2000 (PSSR)
- 5) Control of Substances Hazardous to Health Regulations 2002 (COSHH) (as amended 2004)
- 6) Workplace (Health, Safety and Welfare) Regulations 1992 (WHSWR)
- 7) Lifting Operations and Lifting Equipment Regulations 1998 (LOLER)
- 8) Control of Noise at Work Regulations 2005 (NWR)
- 9) Electricity at Work Regulations 1989 (EWR)
- 10) Personal Protective Equipment at Work Regulations 1992 (PPER) (as amended)
- 11) Manual Handling Operations Regulations 1992 (MHOR) (as amended)
- 12) Regulatory Reform (Fire Safety) Order 2005
- 13) Health and Safety (First Aid) Regulations 1981 (as amended)
- 14) The Reporting of Injuries, Diseases and Dangerous Occurrences Regulations 1995 (RIDDOR)
- 15) The Work at Height Regulations 2005 (WHR) (as amended)
- 16) The Control of Vibration at Work Regulations 2005 (CVW)
- 17) Dangerous Substances and Explosive atmospheres Regulations 2002 (DSEAR)

- 18) Construction (Design and Management) Regulations 2007 (CDM)
- 19) The Control of Asbestos Regulations 2006 (CAR)
- 20) Health and Safety (Consultation with Employees) Regulations 1996 (CER)
- 21) Environmental Protection Act 1990
- 22) Control of Pollution (Oil Storage) (England) Regulations 2001
- 23) Disposal of Controlled Waste Regulations 1991
- 24) Environmental Protection (Duty of Care) Regulations 1991
- 25) Controlled Waste (Amendment) Regulations 1993
- 26) Hazardous Waste Regulations 2005
- 27) The List of Waste Regulations 2005
- 28) Control of Artificial Optical Radiation at Work Regulations 2010 (CAORWR)
- 29) Confined Spaces Regulations 1997 (CSR)
- 30) Health and Safety Information for Employees Regulations 1989 (as amended)
- 31) Health and Safety (Display Screen Equipment) Regulations 1992 (DSER)
- 32) Health and Safety (Miscellaneous Amendments) Regulations 2002
- 33) Health and Safety (Safety Signs and Signals) Regulations 1996

8.0 REVIEW

- 8.1 Annual reviews of the Company Health and Safety Management System will be undertaken by the Company Health and Safety Advisor unless significant legislative changes or incident investigation demands earlier review.
- .2 The Company will hold regular meetings in the form of safety committee meetings to ensure effective employee consultation in regard to the effectiveness of the Company's safety management arrangements and control measures.

9.0 AUDIT

- 9.1 Company legislative compliance audits for both works and site will be undertaken by the Company Health and Safety Advisor when requested.
- .2 Site practice audits will be undertaken by the Company Health and Safety Advisor when requested.
- .3 Routine site safety audits will be undertaken by the Company's Contract Managers on an ongoing basis.